



KEY to productivity

# YV1000-1600 Series

You Ji Machine Industrial Company Limited  
CNC Vertical Turning Center



No.92, Huanqiu Rd., Zhuyuan Vil.,  
Luzhu Dist., Kaohsiung City 82142, Taiwan  
Tel: 886-7-695-2669  
Fax: 886-7-695-3301  
Email : youji@ms15.hinet.net

Distributor

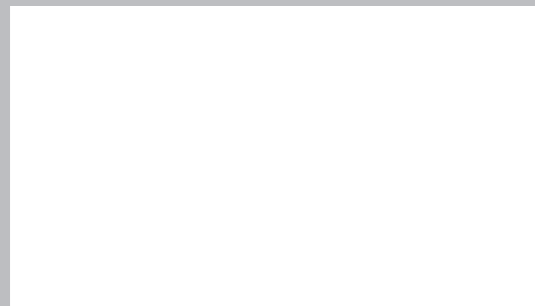

2021.6  
B

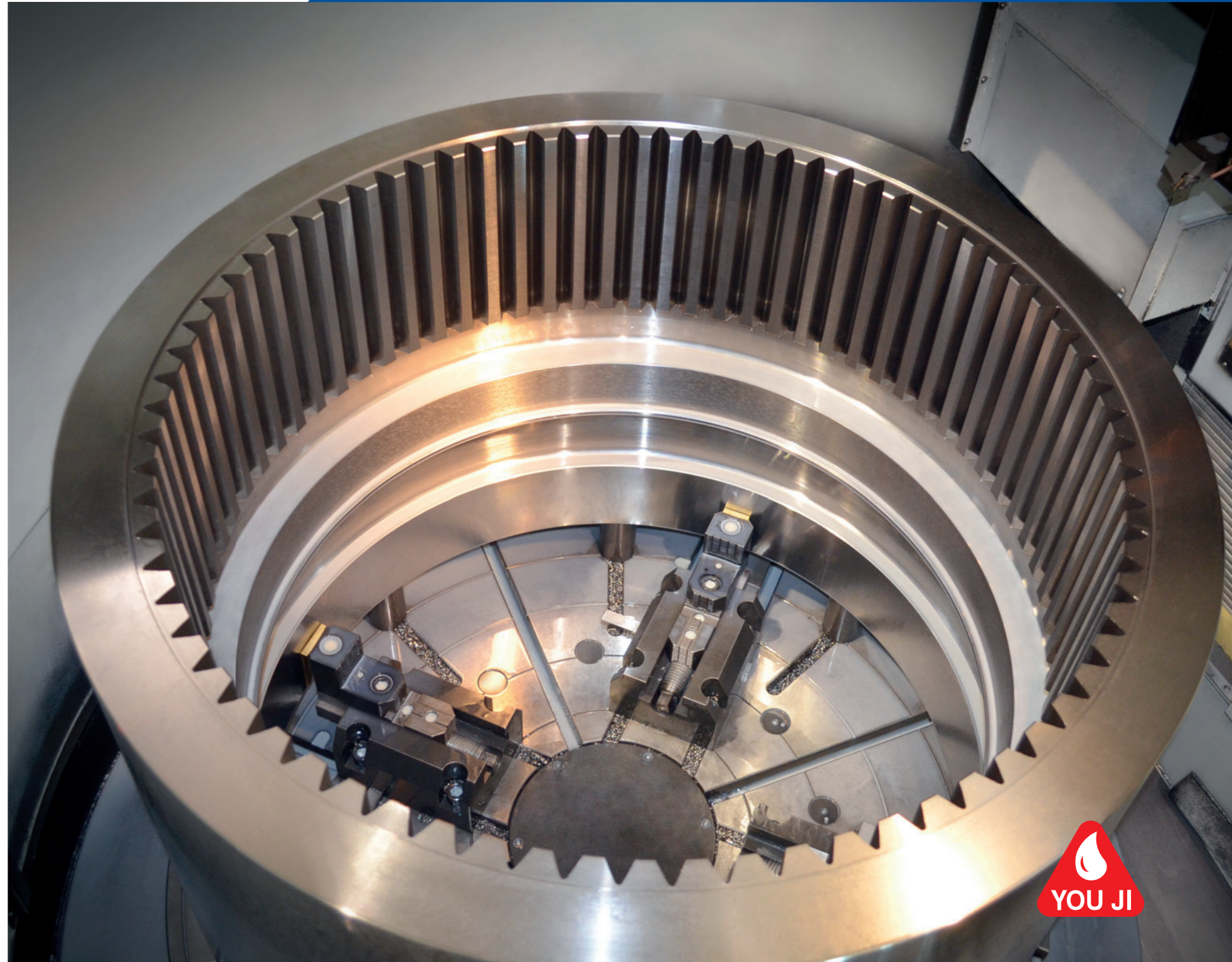

## YV1000-1600 Series CNC Vertical Turning Center



# Leader of Vertical Turning Center

With nearly 40 years of experience, You Ji has a professional R&D design team offering customized integrated solutions to meet individual customers' needs, and excellent after-sales service and management, enabling us to establish lasting relationships with customers. We conduct technology exchange with large manufacturers in other advanced countries and continuously upgrade our technology to enhance our core technical capabilities and provide customers with better, faster, and more comprehensive services.

### Machine Definition

## YV1600ATC+C

A: Vertical Type Turret  
 ATC: Automatic Tool Changer  
 ATC+C: ATC+ C-axis Function  
 Machine Model : 1000, 1200, 1600  
 CNC Vertical Turning Lathe

### Machine Features

- Reduces inertia, avoiding out of round turning problems, achieving optimum accuracy.
- Excellent surface contact between work piece and chuck to ensure high precision turning.
- Suitable for irregular-shape, large, thin, and heavy work piece turning, easy part loading & unloading.
- High rigidity designed machine base for low thermal displacement. The ergonomic design of vertical turning lathes for increased work flow.
- The designed multiple function features give the best cost effective investment.

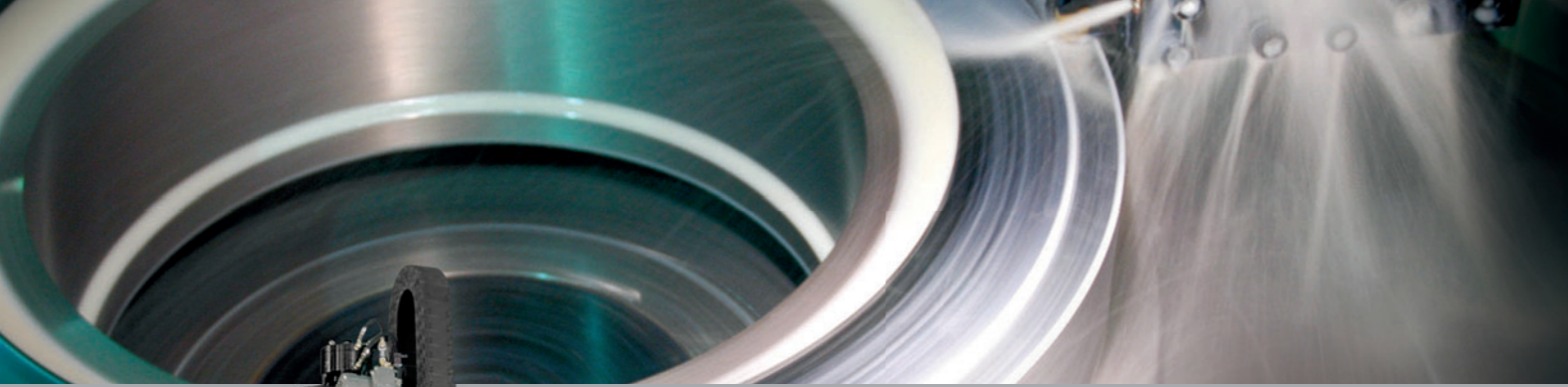

# High Stability Structure

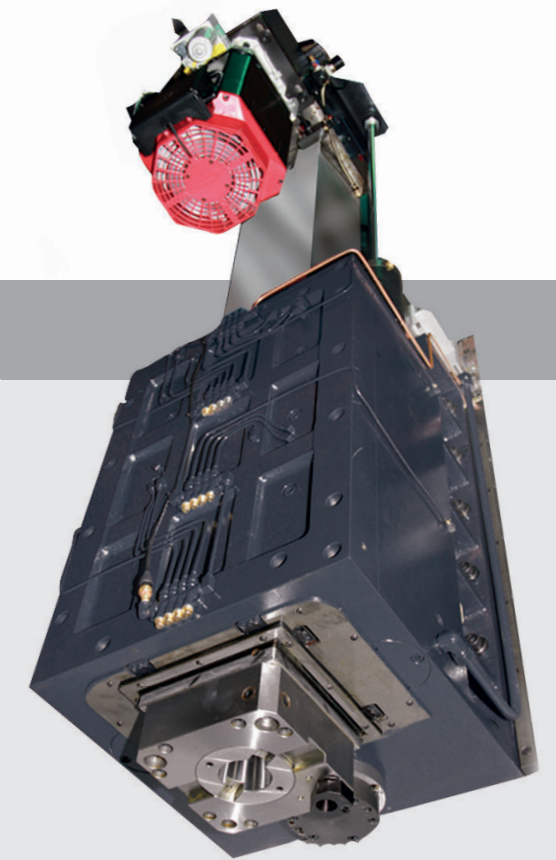

## High Rigidity Structure

The structure of high rigidity box type symmetric column is designed with the finite element analysis (FEA), delivering the perfect performance of machine structure.

Model: YV1200ATC+C

The super large cross section ram is manufactured from the highest grade steel, the ram is fully heat treated and stress relieved. The one piece ram structure is assembled inside the rigid Z axis body. This superbly rigid assembly increases the cutting ability and ensures the turning and machining accuracies inside deep inner diameters.

The built-in coolant system maintains the tool and the work piece at a cool constant temperature. The tool life is extended so reducing machining costs.

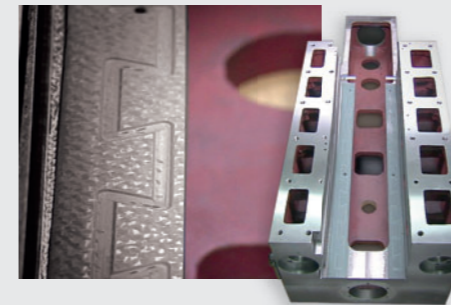

Z axis box guide way is induction hardened and precision ground, the mating sliding faces are Turcite B coated allowing slide assemblies to move with ease and low friction.



The crossrail is movable to suit the work piece height, the movement is obtained by lead screws via a reduced motor, the crossrail is hydraulically clamped by 4 powerful hydraulic cylinders after positioning.

## Machine Base and Column

The high rigidity box type column structure is fitted to machine base. The heavily walled and multi ribbed design minimizes the thermal distortion, withstanding static and dynamic torsion, ensures a high rigid and stable machine assembly.

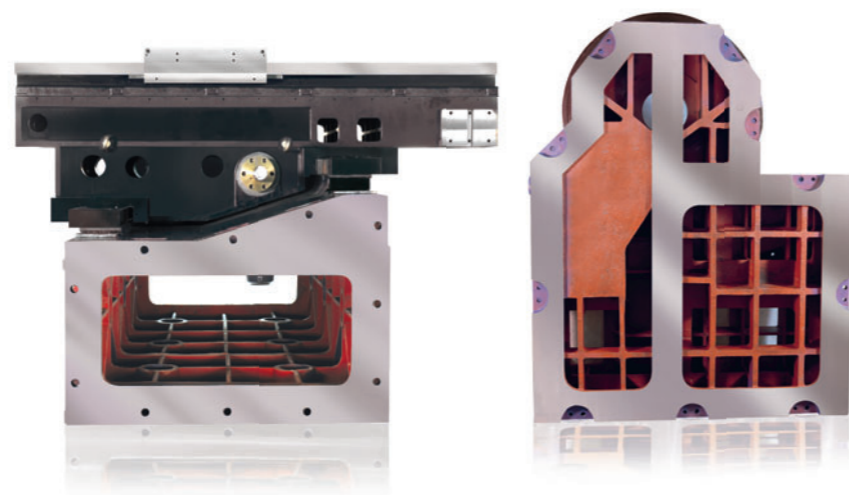

## X&Z Axes Box Guideways

The X/Z axis box guideway are induction hardened and precision ground, the mating sliding faces are Turcite-B coated allowing slide assemblies to move with ease and low friction.

Automatic central lube feeding system control volume and timing of lubrication. Wide span X axis box guideway design brings high stability during long cutting time.



# High Precision Spindle

The large vertical turning lathes are fitted with crossed roller bearing, featuring high precision, high loading and high rigidity design is achieved during manufacturing large and non-symmetric work pieces.

## Comparison Table You ji design / Comparison of competitor models

### Features of crossed roller bearing

- Two rows of rollers in the space of one.
- Saves space and lowers the machine base height for ease of operation.
- Low centre of gravity in the machine and low centrifugal forces.
- Nylon separators feature low inertia, ensuring the machine operation under low running torque.
- Heat dispersion and wear-resistant for longer bearing life.
- Provides high rigidity, high precision, shock-resistant and ease of lubrication.

Radial load : ★★★★★ Load capacity : ★★★★★  
 Axial load : ★★★★★ Service life : ★★★★★

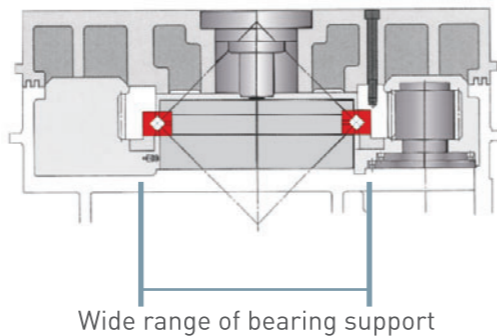

### Radial single row bearing (Comparison of competitor models)

- Radial running load is weak.
- Working point of bearing is far away to work piece.
- High friction and axial thermal displacement.
- High wear and short bearing life.

Radial load : ★★ Load capacity : ★★  
 Axial load : ★★★★★ Service life : ★★

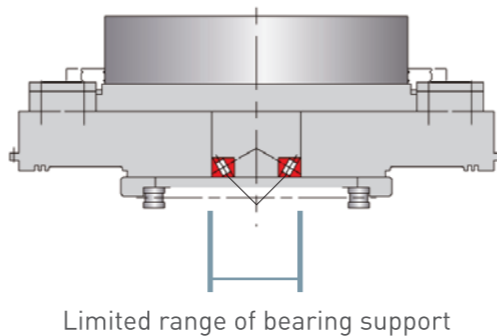

## Torque chart

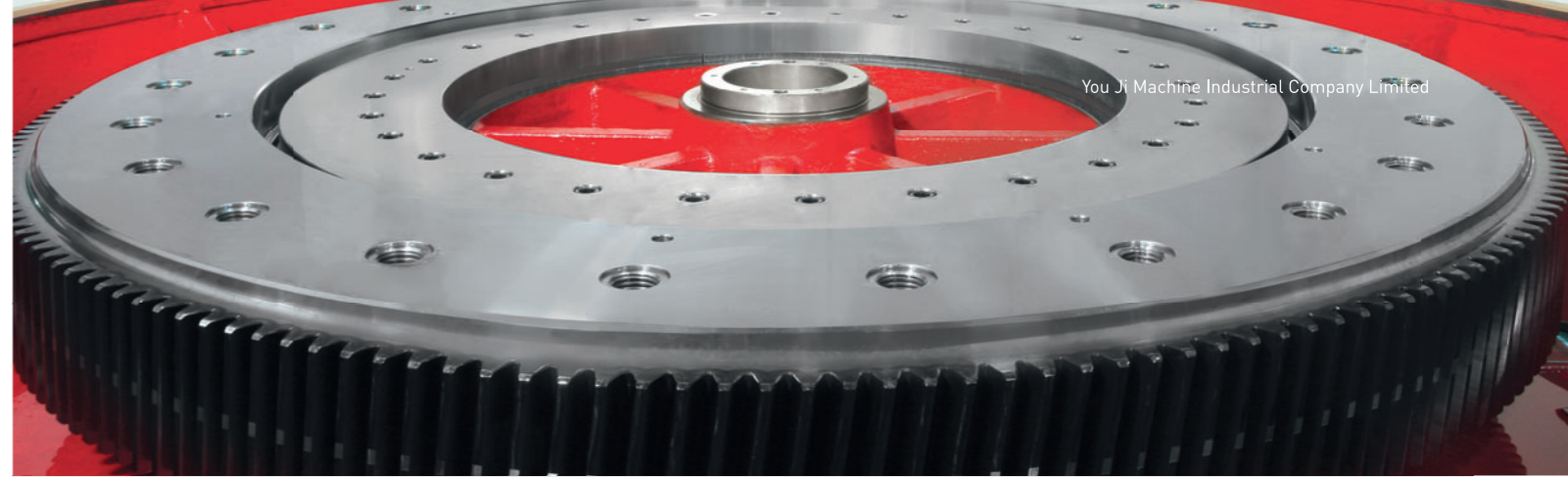
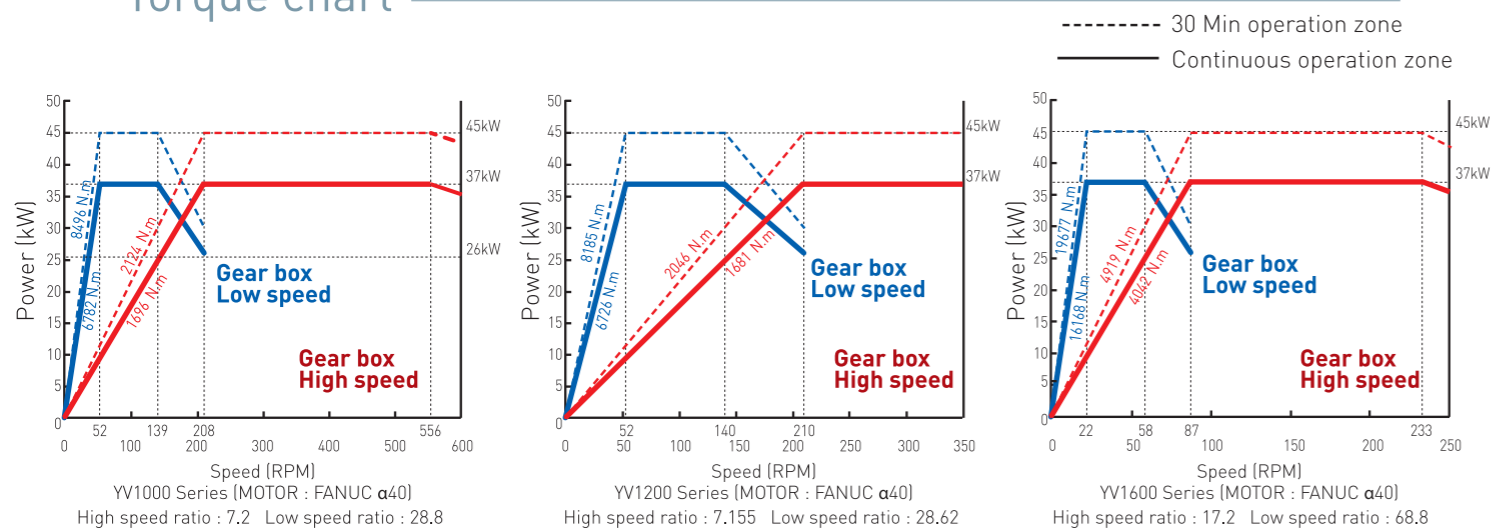

# High Efficiency Transmission

High grade nickel-chrome alloy steel is used for the driven gear. Correct heat treatment and accurate grinding allows it to be classified as first class precision in the Japanese JIS 1 standards.

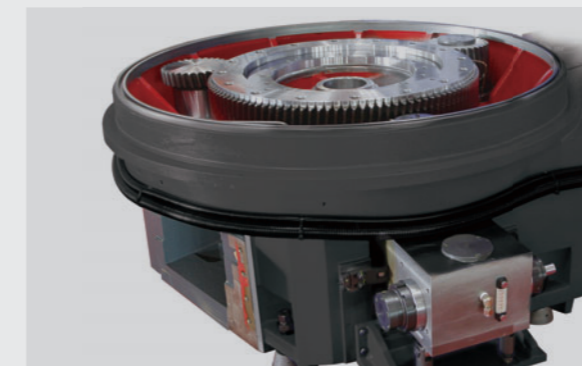

## CF axis

High precision CF axis gearbox delivers precise positioning accuracy, coupled with the functions of a machining center that allows for a wide range of work to be carried out in one set up, so reduces investment costs & machining costs.

## Features of Dual Speed Gearbox

- Eliminates noise and heat transmission to spindle assembly.
- Eliminates vibration transmitted to the spindle.
- Separate lubrication systems for spindle and gearbox eliminate heat transmission.
- High transmitted efficiency ( over 95% )
- Gear shift is controlled by integrated shift system.

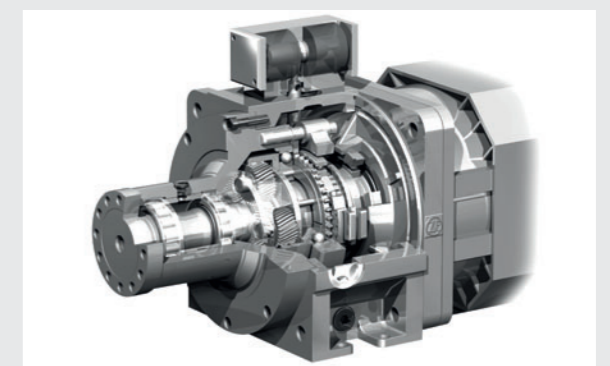

## ATC Tooling system

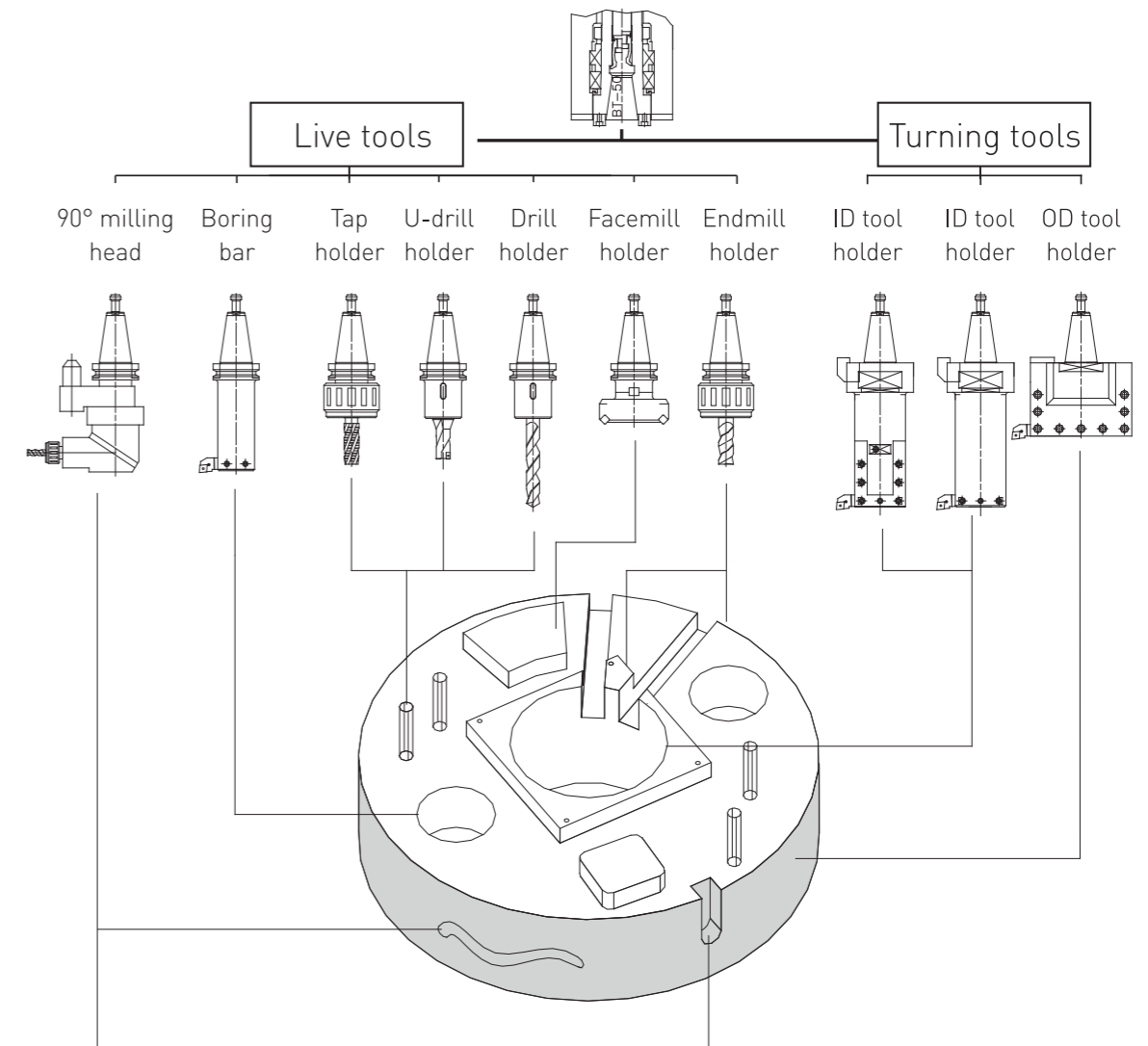

# Best Complex Turning and Machining Solutions

## Live Spindle and Torque Chart

The live spindle motor ( ATC+C series ), coupled with the dual speed gearbox is located on top of the RAM, driving the live spindle via drive shaft. The use of the dual speed gearbox on the live spindle enables high torque output for face milling, end milling, drilling, and tapping capacity.

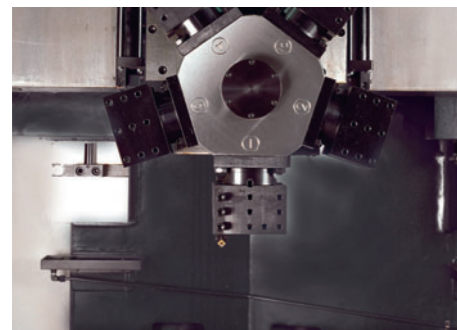
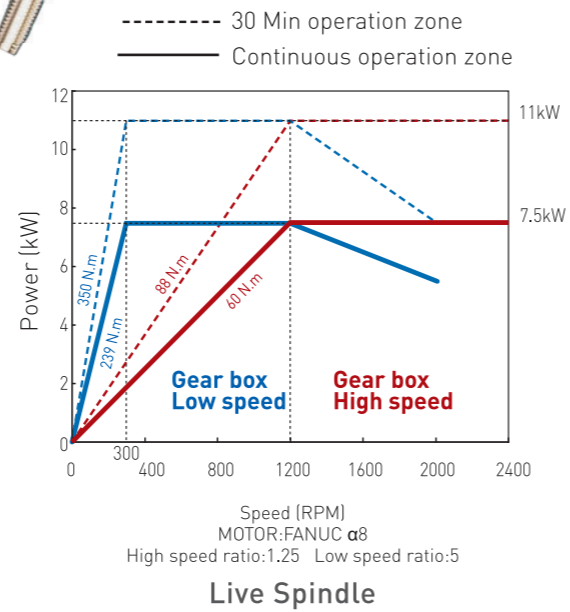

## A type Turret

Turret positioning is achieved with high accuracy curved coupling, providing positioning accuracy of 5" and repeatability 3". Turret with curved coupling withstands heavy cutting forces, a high torque hydraulic motor ensures smooth rotation. The speed of turret rotation and tool change is controlled by a cam system. The PLC ensures the shortest route and bi-directional tool selection reducing the tool change time.



Grinding

Milling

90° drilling

Tapping



Boring

U drilling

Drilling

Turning

# Coromant Capto® System

Coromant Capto® is a modular quick change tooling concept offering three systems in one.

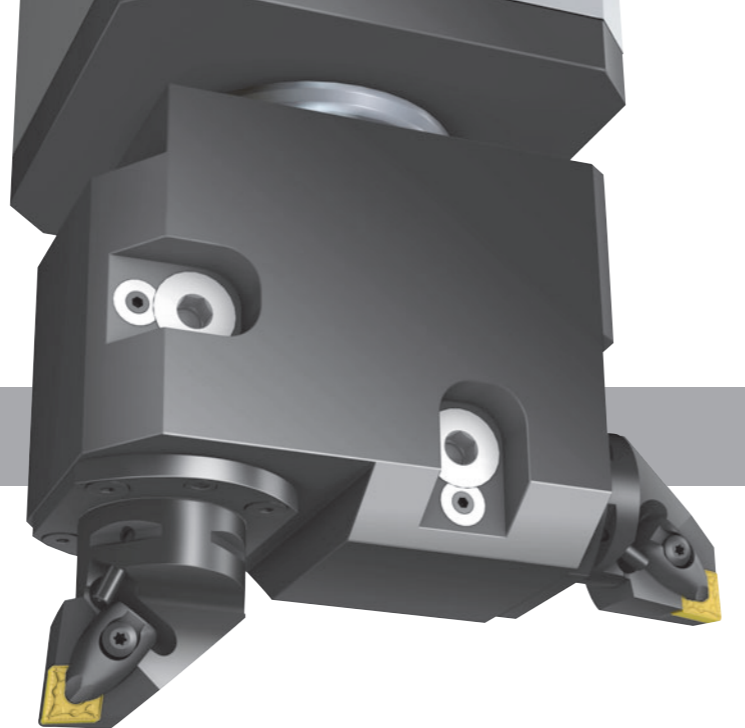

## Offset sleeve

The offset sleeve is designed for boring bar applications. It allows boring bars to reach into smaller diameters than the RAM can access.

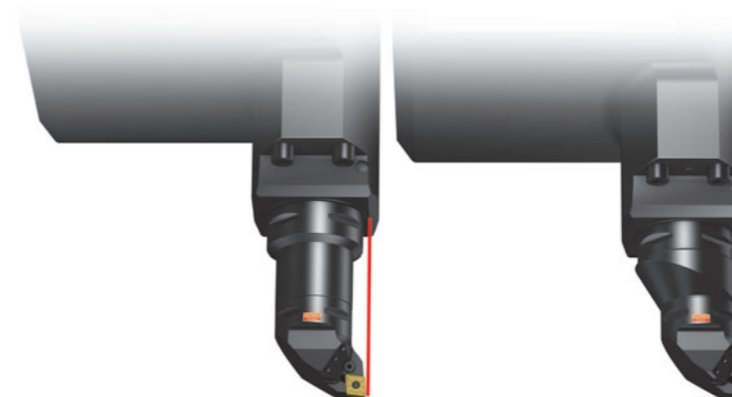
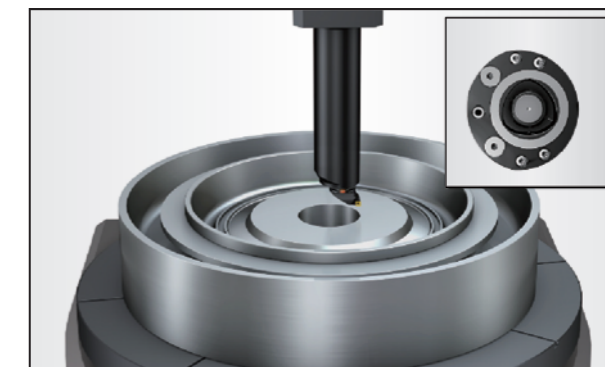

## Offset reduction adaptor

By using an offset reduction adaptor, access to a larger cutting unit program with the same RAM clearance is possible.



## Coromant Capto® versus shank tools

Ease of use for the operator – changing large tools on VTLs with big heavy shank tools is more demanding than horizontal lathes and also setting the offset position takes longer time – 15mins on average reduced to 1 min.

\*Coromant Capto® is a registered trademark by Sandvik.



Coromant Capto® 系統



## CoroTurn SL70 – Serration Lock modular system

Developed for large diameter component features requiring profiling and grooving. The coupling is oval providing extreme rigidity combined with excellent accessibility. Clearance is applied to the blades for axial as well as internal machining so each blade can be used in any configuration. With a range of blades and adaptors this modular system removes the need for special or modified tools. Needless to say, HP is standard.



# How much can you save?

## CoroTurn HP - Combining high pressure, optimized cutting tools and quick change will increase the speed of payback of investment significantly due to:

- Fixed nozzle position – no need for operator setting
- Chip control – reducing machine stoppages
- Increase cutting speed – higher productivity

High pressure coolant (HPC) – Piping the coolant through the RAM means there are no moving parts to provide sealing headaches (like rotating spindles and turrets). 70 bars is now the norm with 200bar being used in difficult to break materials. High pressure coolant systems combined with dedicated tooling eliminates coolant pipe setting and long chips 'bird nesting' around tools and 'bailing' in the conveyor - removing a high percentage of machine stoppages.

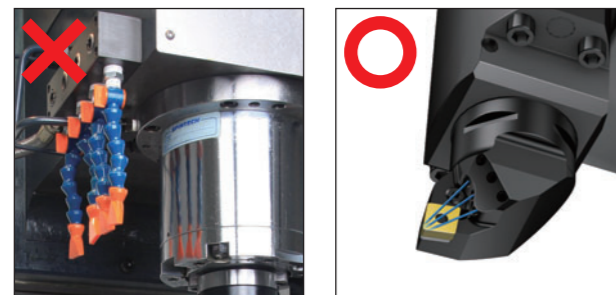
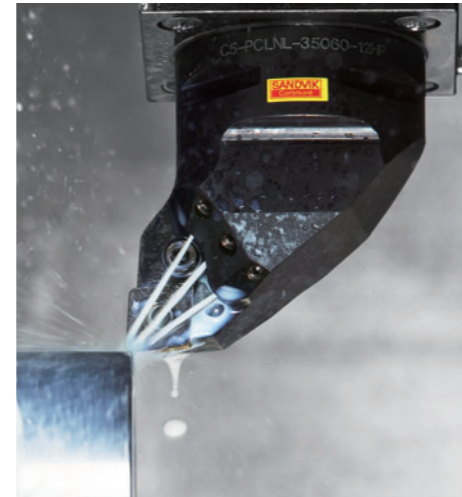

### Coolant pipe setting is eliminated

when operators are setting the coolant pipe direction it normally takes 2 to 3 attempts to get it right. Poor chip control often then knocks the pipe and so setting is quite a regular occurrence – red light on!

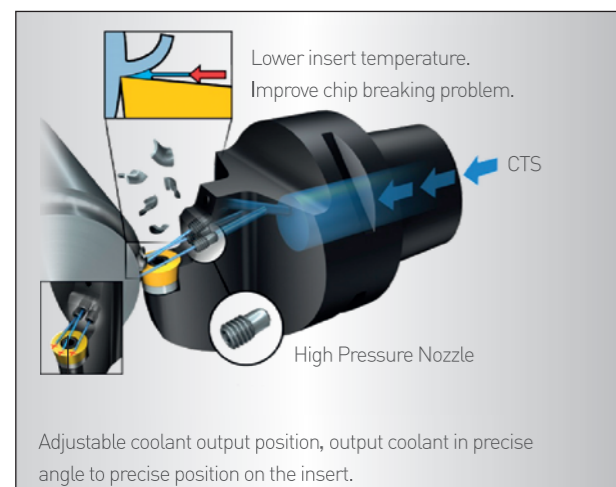

### High Pressure CTS

(20 bar ~ 100 bar)

- Reduce cutting temperature effectively, which prolongs the durability of tools, and also improve production efficiency, thus lower production cost.
- Improve 20% cutting speed in rough machining.
- Improve 50% tool durability.
- Better chip breaking result.

Quicker production start up – using pre-setting outside the machine eliminates 'measuring cuts' and operator errors which is a high risk when using shank tools. The best analogy is the pit stop in motor racing. Calculated through the year if quick change was used the extra machining time is significant not to mention the higher cutting data from increased stability.

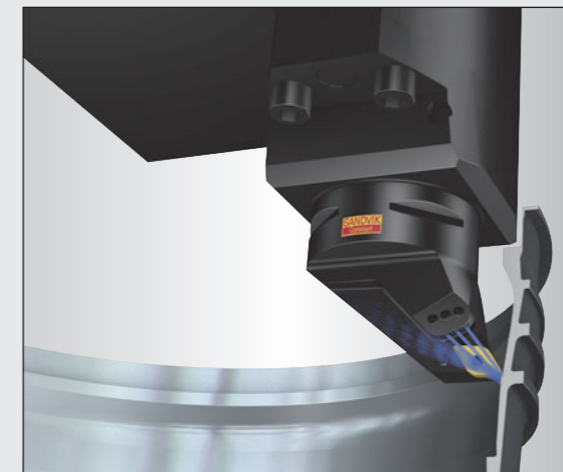

**Example : Coromant Capto® manual Quick Change**  
**Component : aero engine casing**  
**Material : titanium**  
**14 turning tools**

Time reduced for set up from 220 mins to 25 mins with pre-measuring off line Coromant Capto® interface combined with CoroTurn HP cutting units and a 70 bar coolant pump ensured simple and accurate coolant delivery reducing the actual machining time by 30%

## CoroTurn® HP for 'green light' production

Coromant Capto® automatically directs the coolant to the nozzles. The precision nozzles target the correct point on the insert at a low trajectory angle, creating a hydraulic wedge between the chip and the rake face of the insert. The benefits:

- Chip control – reduced stoppages
- Fixed precision nozzle – consistent process
- Increased tool life +50%
- Increased productivity +20% cutting speed

The relatively small investment to have the machine optimized for high pressure offers a very fast payback with continual delivery.



# Safety & Operator-friendliness

## HMI - Human Machine Interface

### Tool monitoring system

Tool monitoring system is one of the safety functions to protect the tool and spindle against possible damages caused by tool wear, breakage, or any other factors lead to abnormal load. This system is developed with following features:

- Easy operation
- Optimum feedrate control
- Longer tool life
- Higher efficiency

### Task manager

All-in-one screen shows all the work-related information in one screen, displayed info including:

- Parts program
- Mechanical coordinates
- Spindle load
- Axes load
- Real-time cut monitoring

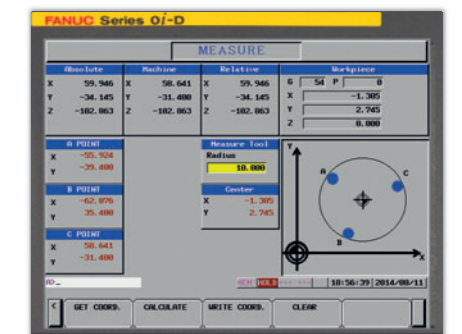
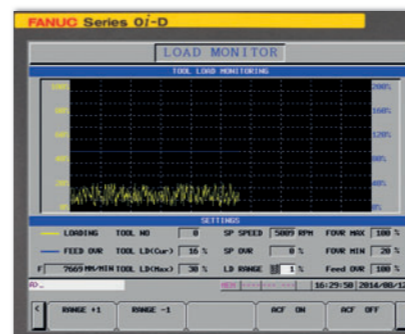

### Safety features

The YV Series machines are very safe to use as they are designed to be as safe as possible. We are always looking for ways to improve all aspects of machine safety - including clamping stroke sensor, door interlock, safety window, etc. - to create the most safe and comfortable working environment for worldwide You Ji machine users.



Safety window



Clamping stroke sensor



Door interlock

## Automatic Tool Changer ( ATC )

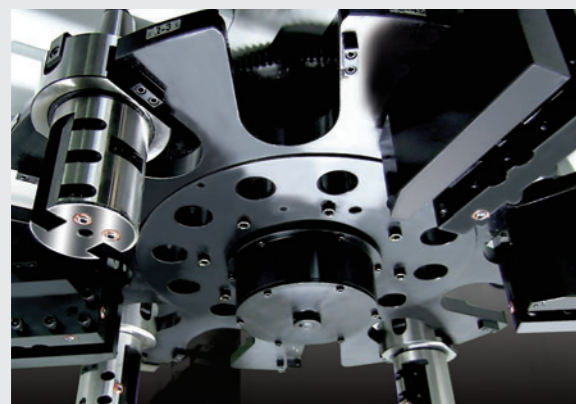

### Disc type Tool Magazine

The design of ATC has shortest route bi-directional tool selection, a safe and ergonomic design feature.

- 12 tools position ( ATC ) and 16 tools position ( ATC+C )
- Max. weight of single tool holder: 50kg
- Max. loading weight of tool magazine: 360kg

### Chain Type Tool Magazine

The servo-driven chain type ATC tool magazine for YV machines features:

- Innovative structure for simplified installation and saving maintenance cost.
- Continually running chain with minimal interlink gap has long service life, quiet operation.
- Highly-stable, simply-structured driving and chain-positioning modules.
- Available with 32, 48, 60 or more tool positions.



# Dimension of Tool Holder

Unit:mm

## A type

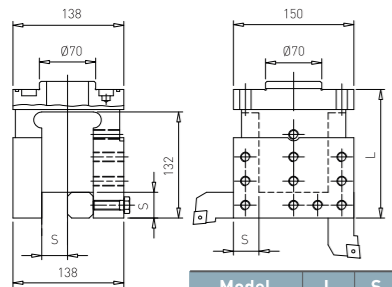

Model	L	S
STA1-160	160	32
STA1-200	210	32

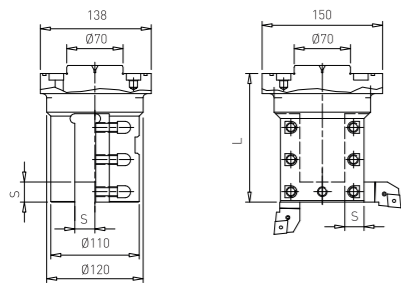

Model	L	S
STA2-160	160	25
STA2-210	210	25
STA2-260	260	25

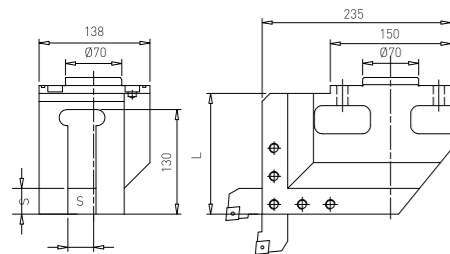

Model	L	S
STA3-160	160	32

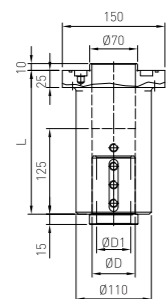

Model	L	ØD	ØD1
STA4-160	160	63	20,25,32,40,50
STA4-210	210	63	20,25,32,40,50
STA4-260	260	63	20,25,32,40,50

## ATC Series

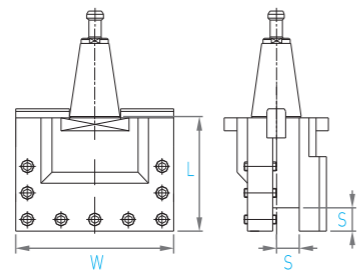

\*DT : dual contact

Model	W	L	S
BT50-STST16032	220	160	32
BT50-STST16040	220	160	40
BT50-DTST16032	220	160	32
BT50-DTST16040	220	160	40

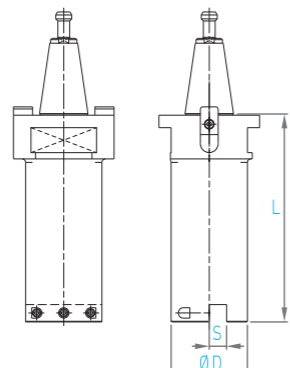

\*DT : dual contact

Model	L	S	ØD
BT50-STBB20025	200	25	100
BT50-STBB30025	300	25	110
BT50-DTBB20025	200	25	100
BT50-DTBB30025	300	25	110

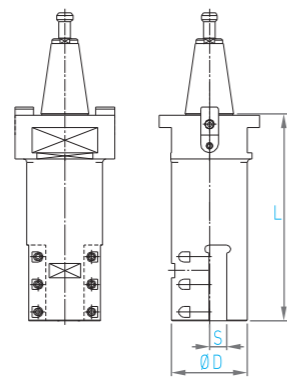

\*DT : dual contact

Model	L	S	ØD
BT50-STBT20025	200	25	100
BT50-STBT30025	300	25	110
BT50-DTBT20025	200	25	100
BT50-DTBT30025	300	25	110

## ATC+C Series

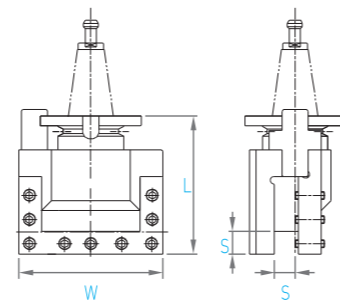

\*DM : dual contact

Model	W	L	S
BT50-SMST19732	220	197	32
BT50-SMST19740	220	197	40
BT50-DMST21032	220	210	32
BT50-DMST21040	220	210	40

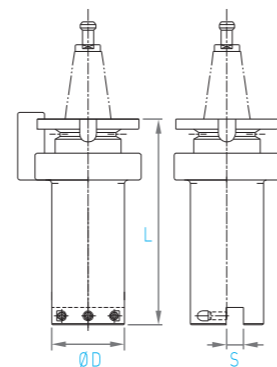

\*DM : dual contact

Model	L	S	ØD
BT50-SMBB20025	200	25	100
BT50-SMBB30025	300	25	110
BT50-DMBB20025	200	25	100
BT50-DMBB30025	300	25	110

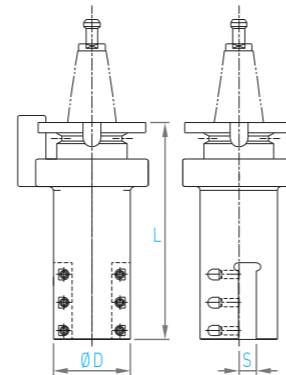

\*DM : dual contact

Model	L	S	ØD
BT50-SMBT20025	200	25	100
BT50-SMBT30025	300	25	110
BT50-DMBT20025	200	25	100
BT50-DMBT30025	300	25	110

## BT + Coromant Capto® (ATC Series)

\*DT : dual contact \*Excluded C6 tooling

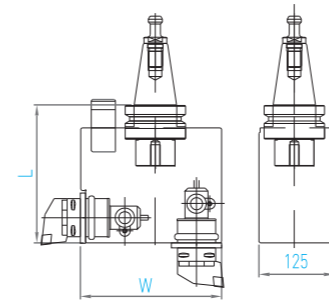

Model	W	L
BT50-STST228-R-C6-HV	234	228
BT50-DTST228-R-C6-HV	234	228

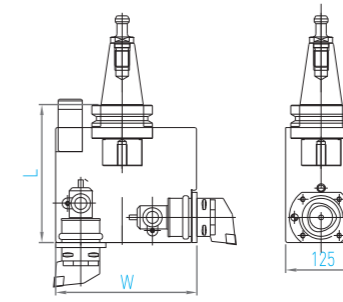

Model	W	L
BT50-STST228-R-C6-VH	234	228
BT50-DTST228-R-C6-VH	234	228

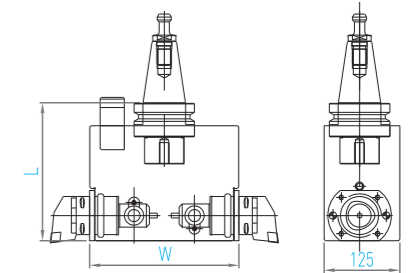

Model	W	L
BT50-STST228-R-C6-HH	247	228
BT50-DTST228-R-C6-HH	247	228

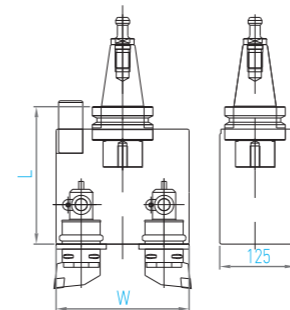

Model	W	L
BT50-STST238-R-C6-VV	220	228
BT50-DTST238-R-C6-VV	220	228

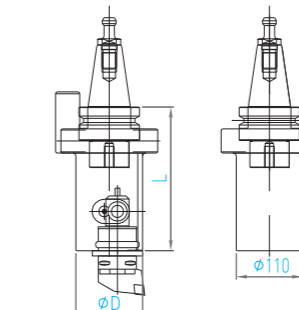

Model	ØD	L
BT50-STBT238-R-C6-V	110	238
BT50-DTBT238-R-C6-V	110	238

## BT + Coromant Capto® (ATC +C Series)

\*DM : dual contact \*Excluded C6 tooling

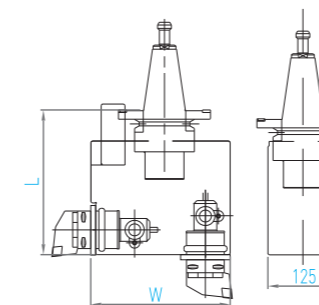

Model	W	L
BT50-SMST242-R-C6-HV	234	242
BT50-DMST242-R-C6-HV	234	242

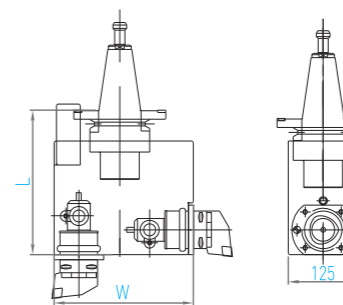

Model	W	L
BT50-SMST242-R-C6-VH	234	242
BT50-DMST242-R-C6-VH	234	242

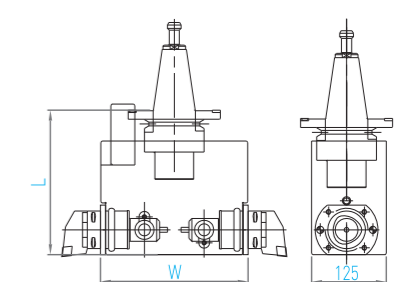

Model	W	L
BT50-SMST242-R-C6-HH	247	242
BT50-DMST242-R-C6-HH	247	242

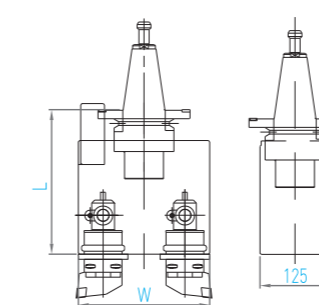

Model	W	L
BT50-SMST242-R-C6-VV	220	242
BT50-DMST242-R-C6-VV	220	242

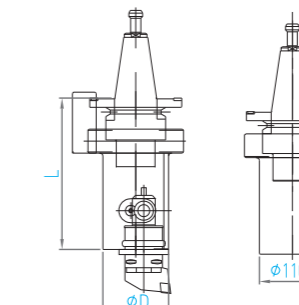

Model	ØD	L
BT50-SMBT253-R-C6-V	110	253
BT50-DMBT253-R-C6-V	110	253



### BT-50

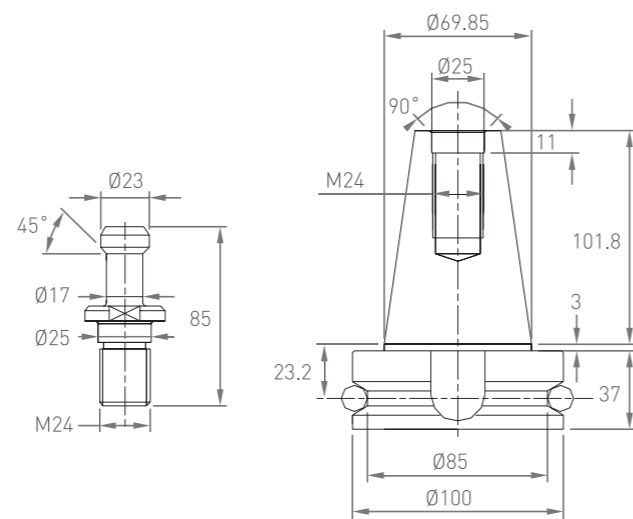

### Max. Tool Dimension

#### BT-50

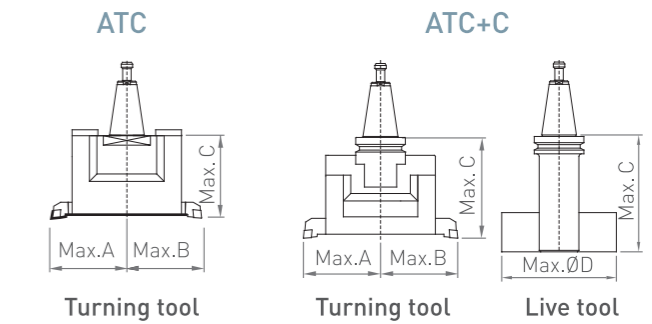
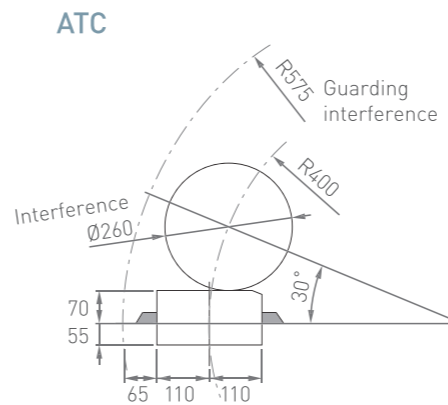

Unit mm

Tool Shank	Model	A	B	C	D
BT-50	ATC Series	155	155	300	
	ATC+C Series	155	155	300	250

\*Please mind tooling interference while using live tools.

### ATC+C Series

Side lock chuck

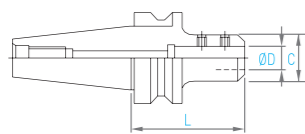

Model	L	C	ØD
BT50-SLA20-105	105	50	20
BT50-SLA25-105	105	55	25
BT50-SLA32-105	105	60	32
BT50-SLA40-105	105	80	40
BT50-SLA50.8-105	105	95	50.8

Facemill holder  
(Milling cutter excluded)

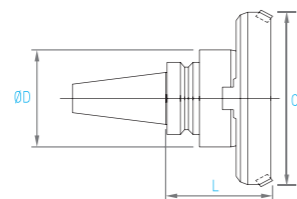

Model	L	C	ØD
BT50-FMA25.4-105	155	80	60
BT50-FMA31.75-105	160	100	70
BT50-FMA38.1-75	130	125	85
BT50-FMA50.8-75	135	150	95

Collet chuck

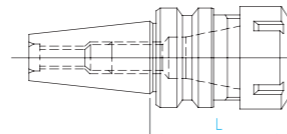

Model	L	Clamping range	Collet type
BT50-ER20-100	100	1-13	ER-20
BT50-ER32-100	100	3-20	ER-32
BT50-ER40-100	100	4-26	ER-40

Boring bar  
(Rough boring)

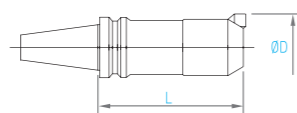

Model	L	ØD
BT50-BSB62-300	300	62-90
BT50-BSB72-285	285	72-110
BT50-BSB105-285	285	105-160

Tap holder

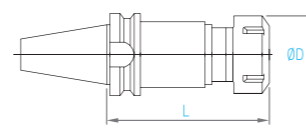

Model	L	ØD	Tapping rang
BT50-TER10	80	28	M4-M10
BT50-TER46	117	63	M6-M27

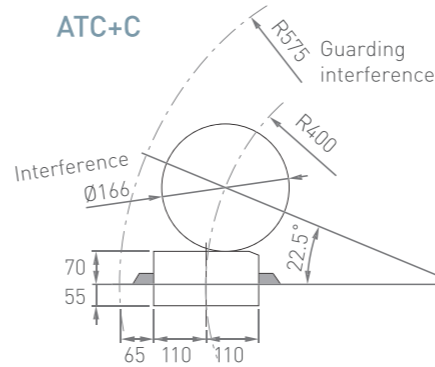

### RAM Interference

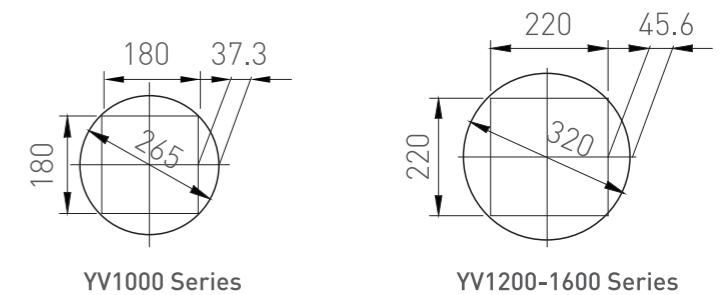

### X axis Travel Diagram

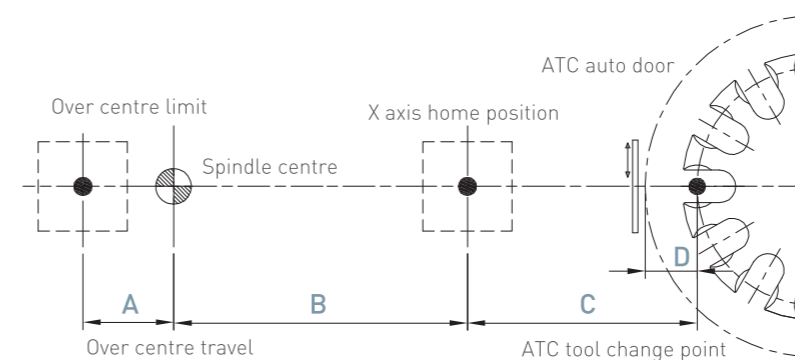

Unit mm

Model	A	B	C	D
YV1000A	400	720	/	/
YV1000ATC	400	720	400	155
YV1000ATC+C	400	720	400	155
YV1200A	100	1230	/	/
YV1200ATC	100	875	400	155
YV1200ATC+C	100	875	400	155
YV1600A	100	1510	/	/
YV1600ATC	100	1125	400	155
YV1600ATC+C	100	1125	400	155

### Diagram of Working Table

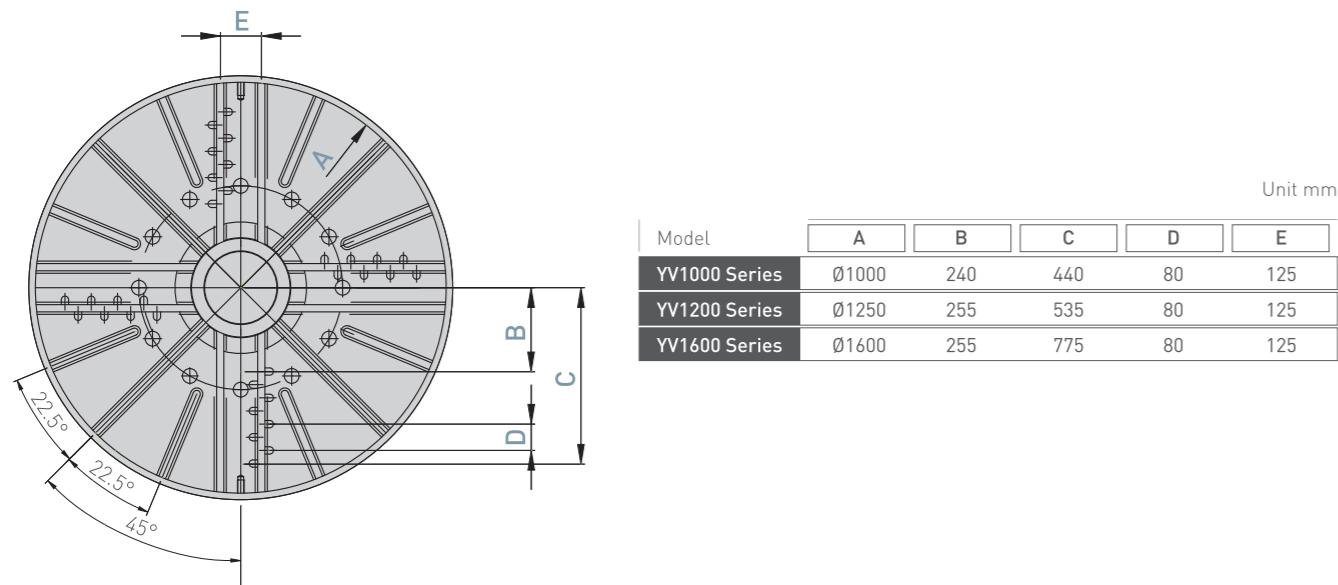

### Dimension of Chuck Jaws - YV1000/1200/1600 Series

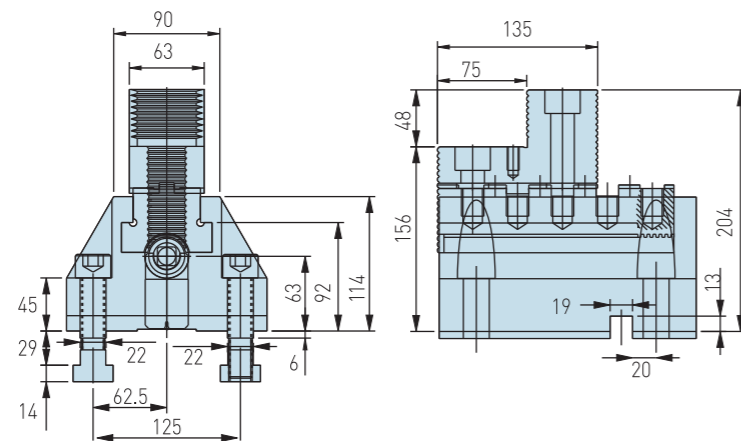

### Clamping for Chuck Jaws

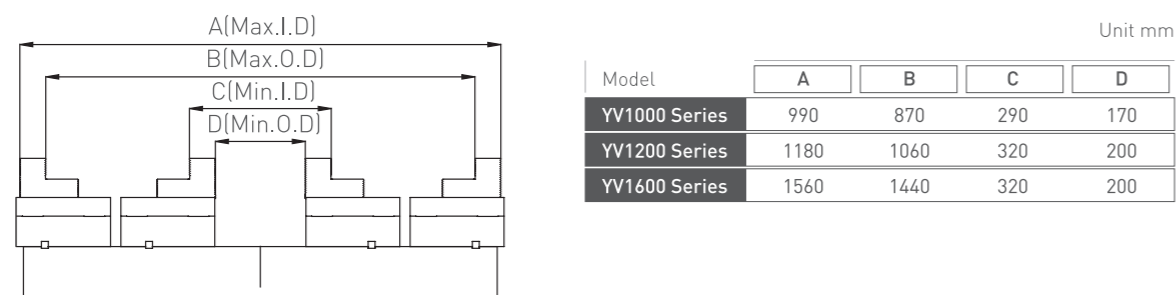

### Machining Range

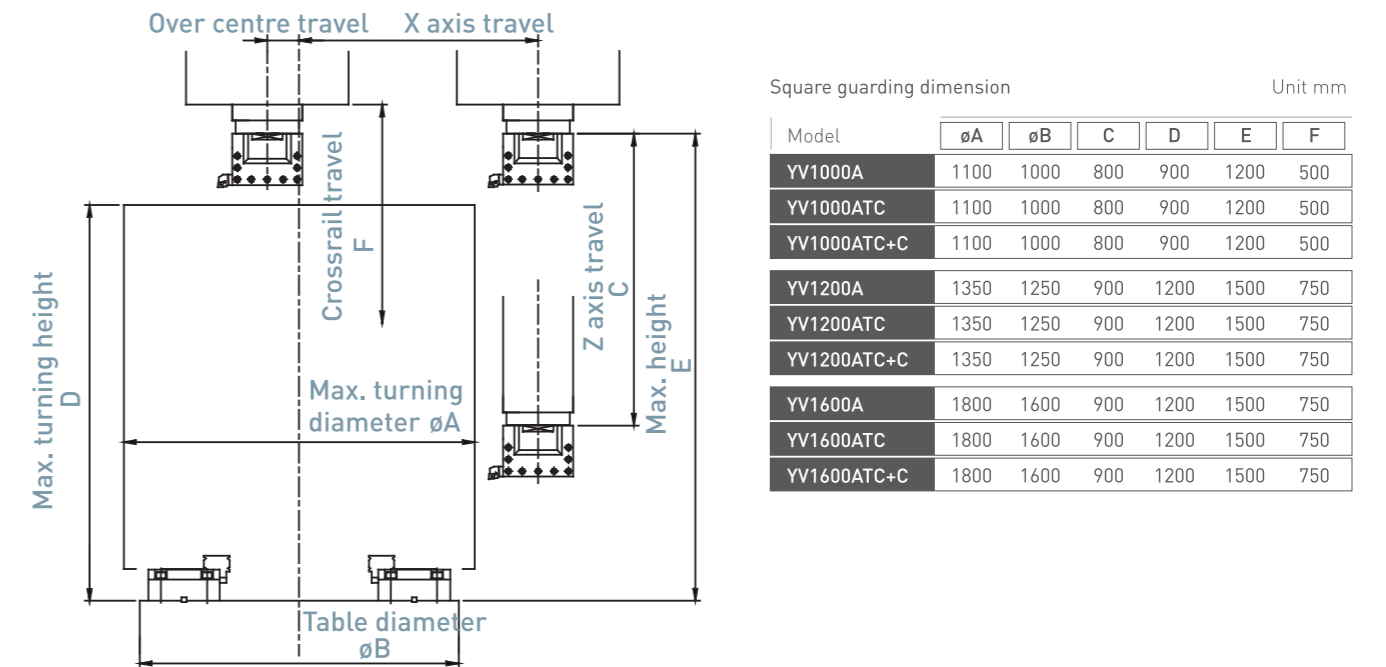

### Machine Layout Dimension - YV1000-1600 Series

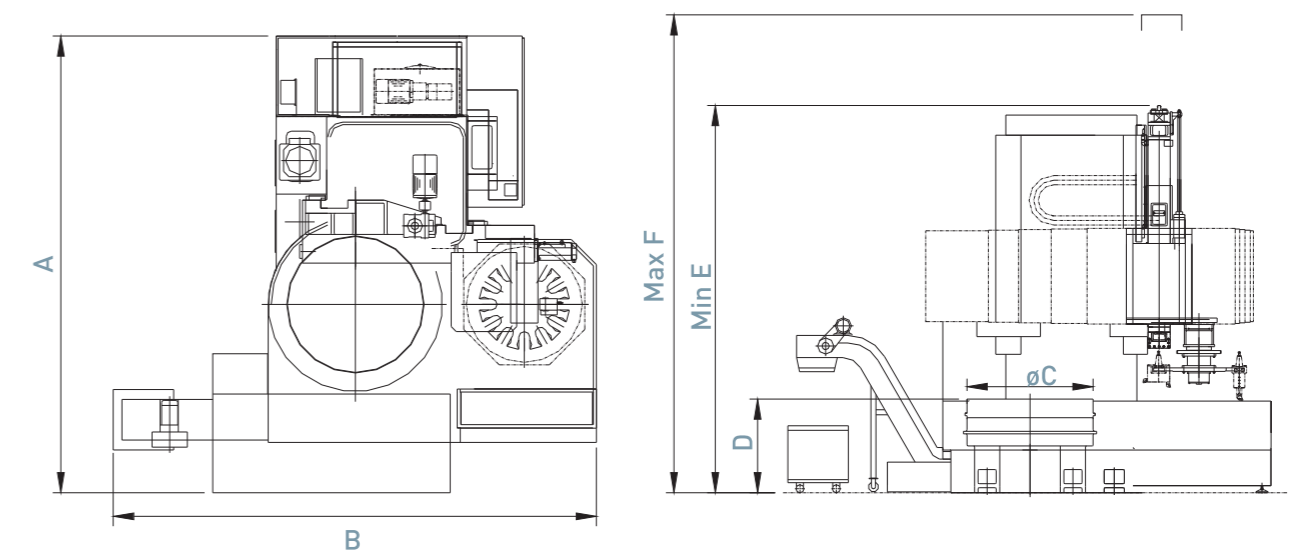

Model	A	B	ØC	D	E	F
YV1000A	4000	4700	1000	980	4450	4950
YV1000ATC	4100	4800	1000	980	4450	4950
YV1000ATC+C	4100	4800	1000	980	4450	4950
YV1200A	4600	5300	1250	930	4550	5300
YV1200ATC	4600	5300	1250	930	4650	5400
YV1200ATC+C	4600	5300	1250	930	4650	5400
YV1600A	5500	5500	1600	910	4550	5300
YV1600ATC	5500	5500	1600	910	4550	5400
YV1600ATC+C	5500	5500	1600	910	4550	5400

Unit mm

# Machine Specifications

Machine Specifications		YV1000			YV1200			YV1600					
Standard Specifications	Unit	A	ATC	ATC+C	A	ATC	ATC+C	A	ATC	ATC+C			
<b>Capacity</b>													
Table diameter	mm	Ø1000	Ø1000	Ø1000	Ø1250	Ø1250	Ø1250	Ø1600	Ø1600	Ø1600			
Max. swing diameter	mm	Ø1350	Ø1350	Ø1350	Ø1600	Ø1600	Ø1600	Ø2000	Ø2000	Ø2000			
Max. turning diameter	mm	Ø1100	Ø1100	Ø1100	Ø1350	Ø1350	Ø1350	Ø1800	Ø1800	Ø1800			
Max. turning height	mm	900	900	900	1200	1200	1200	1200	1200	1200			
Max. work-piece weight	kg	4000	4000	4000	5000	5000	5000	8000	8000	8000			
<b>Travel</b>													
Horizontal of rail head (X axis)	mm	-400, +720	-400, +720	-400, +720	-100, +1230	-100, +875	-100, +875	-100, +1510	-100, +1125	-100, +1125			
Vertical travel of RAM (Z axis)	mm	800	800	800	900	900	900	900	900	900			
Vertical travel of cross rail	mm	500	500	500	750	750	750	750	750	750			
<b>Spindle</b>													
Spindle speed	Low	RPM	1~160	1~160	1~160	1~140	1~140	1~140	1~62	1~62			
	High	RPM	160~600	160~600	160~600	140~350	140~350	140~350	62~250	62~250			
Live spindle speed	Low	RPM	/			2~1200			/				
	High	RPM	/			1200~2400			/				
Max. table torque	N·m (kgf·m)	8,496(867)	8,496(867)	8,496(867)	8,185(835)	8,185(835)	8,185(835)	19,677(2007)	19,677(2007)	19,677(2007)			
<b>Feed rate</b>													
X-axis rapid traverse	m/min	12			12			12					
Z-axis rapid traverse	m/min	10			10			10					
Cutting feed rate	mm/min	1~2000			1~2000			1~2000					
Manual feed rate	m/min	0~6			0~6			0~6					
<b>Automation Tool Changer (ATC)</b>													
Number of tool position		12 tools		16 tools		12 tools		16 tools		12 tools			
Type of tool shank		7/24 taper BT-50				7/24 taper BT-50				7/24 taper BT-50			
Max. tool length of ATC	mm	380				380				380			
Max. tool weight	kg	50		50		50		50		50			
Max. loading weight of ATC	kg	360		360		360		360		360			
Time of tool change (tool to tool)	sec	5		40		5		40		5			
<b>Turret</b>													
Turret type		5 station			5 station			5 station			/		
Size for square tool holder	mm	□32x32(Ø63)			□32x32(Ø63)			□32x32(Ø63)			/		
<b>CNC Controller</b>													
FANUC 0i-T													
<b>Motors</b>													
Spindle motor	kW	37/45 (α40)	37/45 (α40)	37/45 (α40)	37/45 (α40)	37/45 (α40)	37/45 (α40)	37/45 (α40)	37/45 (α40)	37/45 (α40)			
Live spindle motor	kW	/			7.5/11 (α8)			/			7.5/11 (α8)		
X axis servo motor	kW	7 (α30i)			7 (α30i)			7 (α30i)					
Z axis servo motor	kW	6(α40i+β)			6(α40i+β)			6(α40i+β)					
CF axis servo motor	kW	/		7 (α30i)		/		7 (α30i)		7 (α30i)			
Coolant pump	kW	1.5	1.5	1.5	1.5	1.5	1.5	1.5	1.5	1.5			
Power capacity	KVA	85	85	105	85	85	105	85	85	105			
<b>Tank capacity</b>													
Hydraulic tank	L	60		130		130		130					
Coolant tank	L	700			570			550					
Lubrication tank	L	4.6			4.6			4.6					
<b>Machine Dimension</b>													
Floor dimension	mm	4000 x 4700	4100 x 4800			4600 x 5300			5500 x 5500				
Machine height	mm	4950			5300		5400		5300		5400		
Machine weight	kg	20,000	20,000	21,000	22,000	22,000	23,000	24,000	24,000	25,000			
<b>Accuracy</b>													
X & Z-axis	mm	P : ±0.007/500, Ps : ±0.005			P : ±0.007/500, Ps : ±0.005			P : ±0.007/500, Ps : ±0.005					
C-axis		P : ±7.5"/360°, Ps : ±5"			P : ±7.5"/360°, Ps : ±5"			P : ±7.5"/360°, Ps : ±5"					

\* Specification is subject to change without prior notice.

## STANDARD ACCESSORIES

- FANUC 0i-T controller
- 4 jaws manual chuck  
YV1000 (40")  
YV1200 (49")  
YV1600 (63")
- Dual speed gearbox
- Hydraulic unit
- Coolant unit
- Pressure relief automatic lubrication system
- Air conditioner for electrical cabinet
- Chip conveyor and chip bucket
- Working lamp
- 5 station turret ( A- Series )
- 12 positions tool magazine ( ATC series )
- 16 positions tool magazine ( ATC+C series )
- Tool box with tools
- Operation manual
- Square guarding



Coolant through spindle

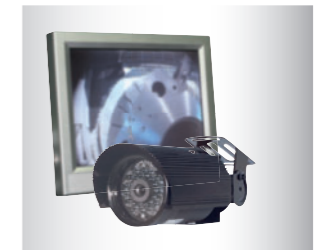

Machine monitoring system



Coolant chiller



Magnetic Chuck

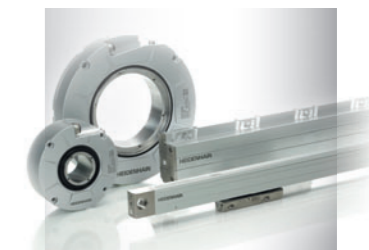

Linear scale



3 jaws, 4 jaws, 6 jaws hydraulic chucks are available as options to reduce valuable set up time.

## OPTIONAL ACCESSORIES

- FANUC 31i controller
- SIEMENS 840D controller
- Tool presetter
- X axis and Z axis linear scales
- 3/4/6 jaws hydraulic chuck
- Work piece probe
- Paper filter
- Grinding attachment
- Oil skimmer
- Transformer
- Full enclosure guarding
- Pendant control
- Tool magazine for 24, 32, 48, 60+ tool positions
- Tailstock
- Coolant through spindle system (12 Bar)
- Automatic pallet changer
- Dual contact turning tool holder
- Machine monitoring system
- Coolant chiller