

BM SERIES

Super Rigidity Vertical Machining Centers

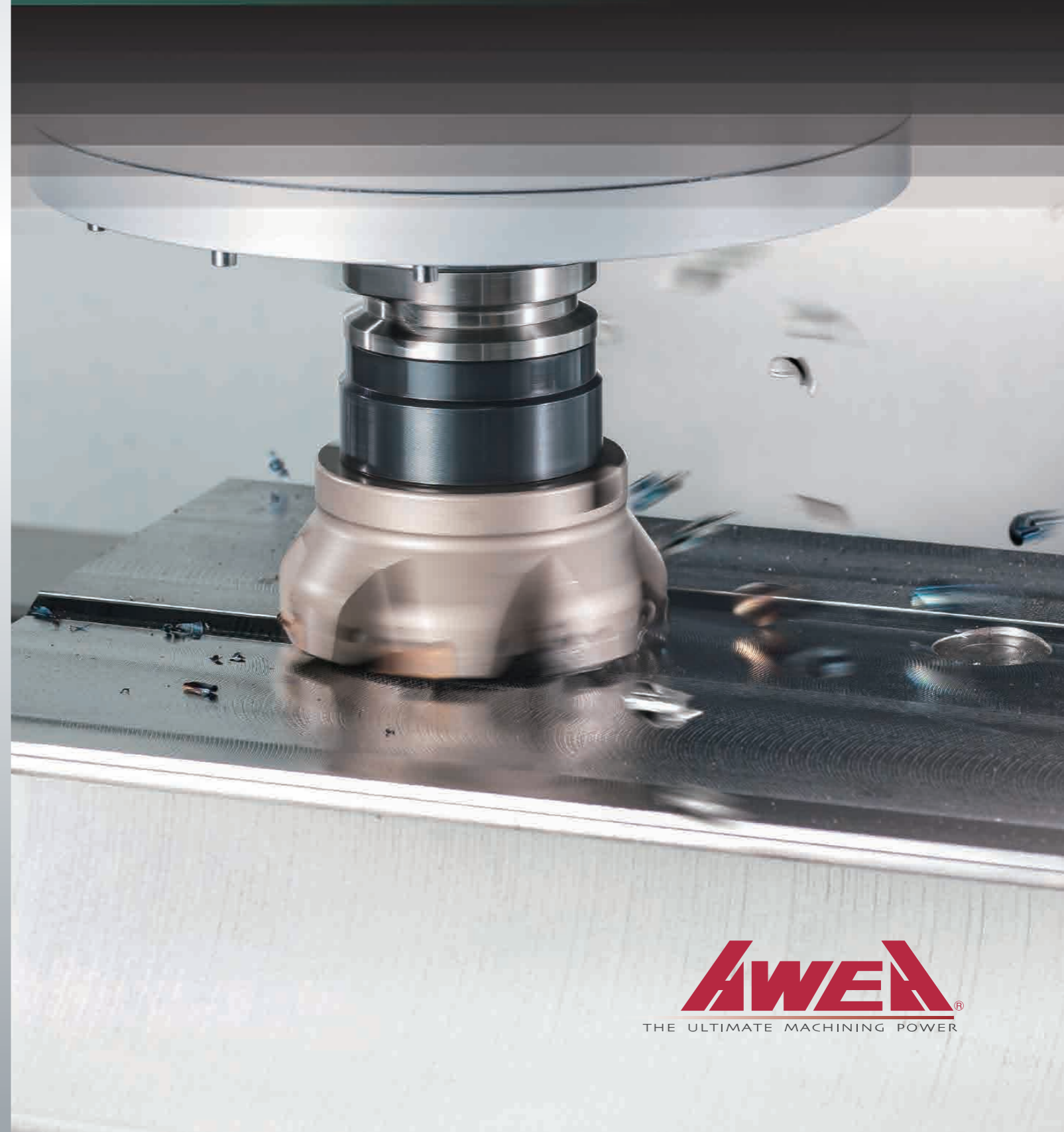

AWEA MECHANTRONIC CO., LTD.

HEADQUARTERS

629, Suezhetou Section, Kwanpu Rd., Wenshan Li,
Hsinpu, Hsinchu 305, Taiwan
TEL : +886-3-588-5191
FAX : +886-3-588-5194
Website : www.awea.com

CENTRAL TAIWAN SCIENCE PARK BRANCH

15, Keyuan 2nd Rd., Central Taiwan Science Park,
Taichung 407, Taiwan
TEL : +886-4-2462-9698
FAX : +886-4-2462-8002
E-mail : sales@awea.com

ISO 9001



ISO 14001



AGENT



SUPER RIGIDITY

Structure Design Providing Ultimate Heavy-duty Cutting Performance

AWEA in house made gear box spindle provides the best torque combination. Box way on 3 axes to fulfill reliable and stable heavy-duty cutting requirement. Precise hand scraping on key contact surfaces to ensure the best support and consistent machine accuracy.

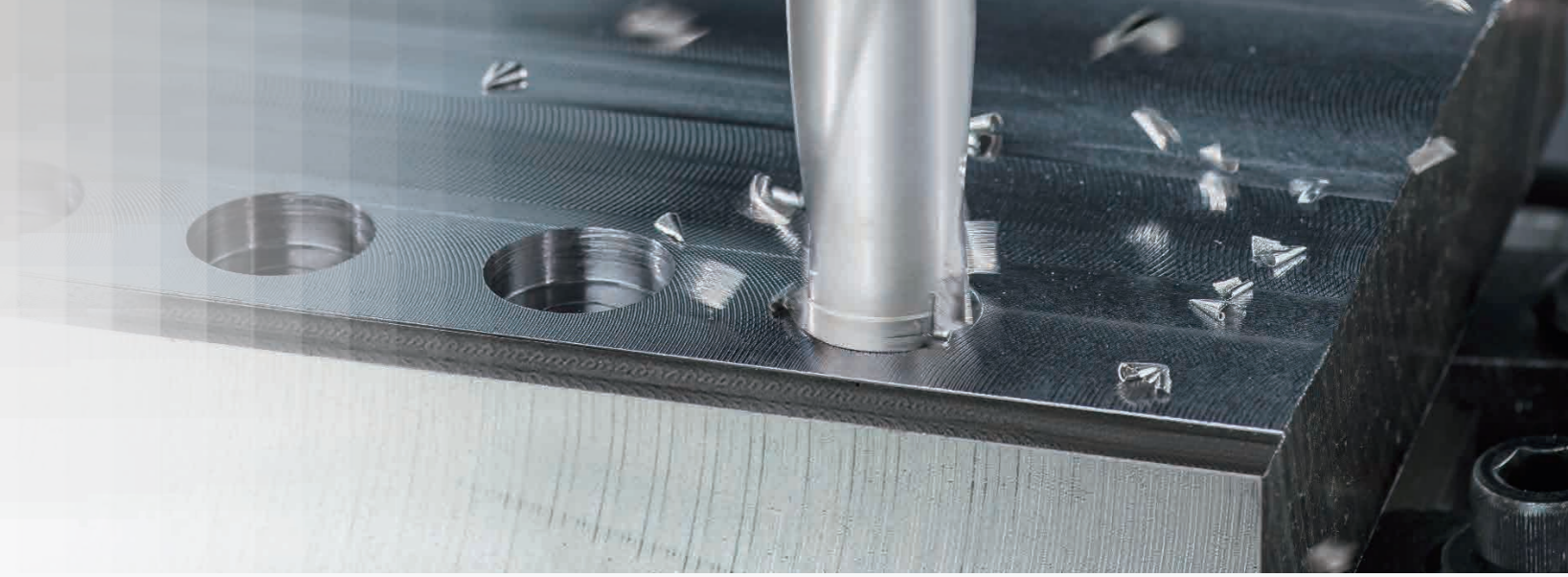

BM-2500
(X : 2,500 / Y : 1,000 / Z : 1,000)



BM-1400
(X : 1,400 / Y : 800 / Z : 700)

BM-850
(X : 850 / Y : 600 / Z : 600)

(Unit : mm)

BM Series 850 / 965 / 1020 / 1165 / 1200 / 1460
1400 / 1600 / 1800 / 2100 / 2500

Super Rigidity Vertical Machining Centers

With the advanced R&D technology and strict quality control, BM series is specially made for heavy cutting machining needs, which have rigid and stable machine structure for extensive application.

BM series offers excellent performance with reasonable and affordable price.

- Depends on the different machining requirement, we provides various modular spindle combinations to achieve optimal cutting performance.
- 3 axes are equipped with box ways which is precisely grinded and throughly heat treated, especially suitable for heavy cutting.
- Highly efficient 24T arm type magazine design provides fast and reliable tool change system.
- The wide range BM series, X travel start from 850 mm to 2,500 mm ; Y / Z travel start from 600 mm to 1,000 mm to meet your various machining requirements.



BM

Series

850 / 965 / 1020 / 1165 / 1200 / 1460
1400 / 1600 / 1800 / 2100 / 2500

Super Rigidity Vertical Machining Centers



- The Finite Element Analysis (FEA) provides optimal machine design and light-weight structure advantage while ensuring super rigidity of machine.
- Δ (Delta) Wide span column construction provides superior cutting stability. The headstock retains stable even under high speed movement.
- Based on BESSEL POINTS concept, provides the stable support on Y-axis saddle to keep in minimum deformation, thus to enhance the table dynamic accuracy.

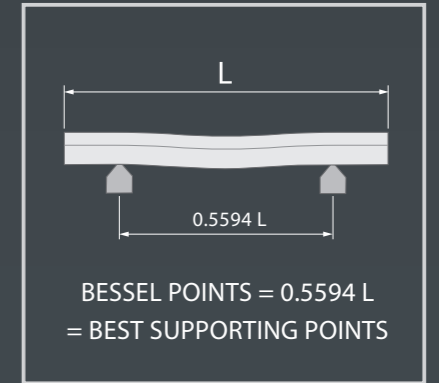

Dual-nuts secured ball screw

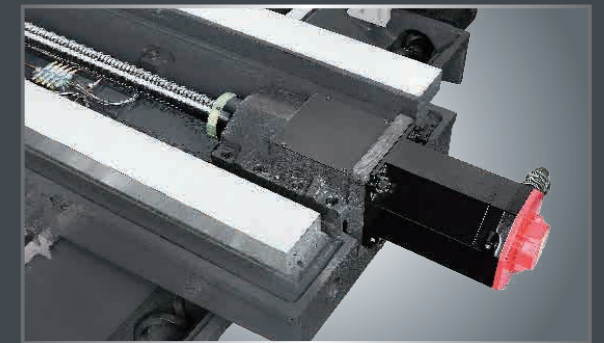

Direct-drive servo motor

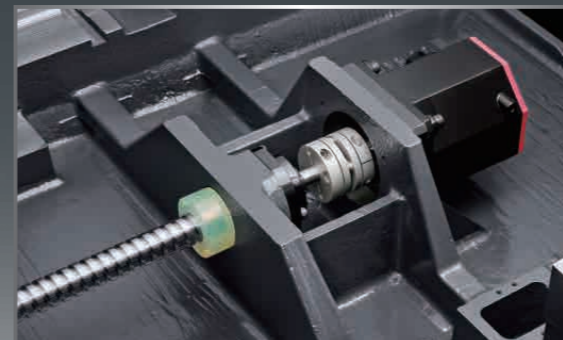

Integrated ball screw servo motor base



Integrated ball screw bearing base

- High precision dual-nuts ball screw provides excellent heavy cutting rigidity while ensuring machining accuracy and extend durability of ball screw.
- Three axial system are adopted with FANUC αi absolute AC servo motor direct drive to provide great thrust and fast acceleration / deceleration movement. Plus, it efficiently decreases motor load and reduces generation of heat while maintaining the ultimate performance and accuracy.

Δ (Delta) Wide span column structure





Series

850 / 965 / 1020 / 1165 / 1200 / 1460
1400 / 1600 / 1800 / 2100 / 2500

Super Rigidity Vertical Machining Centers

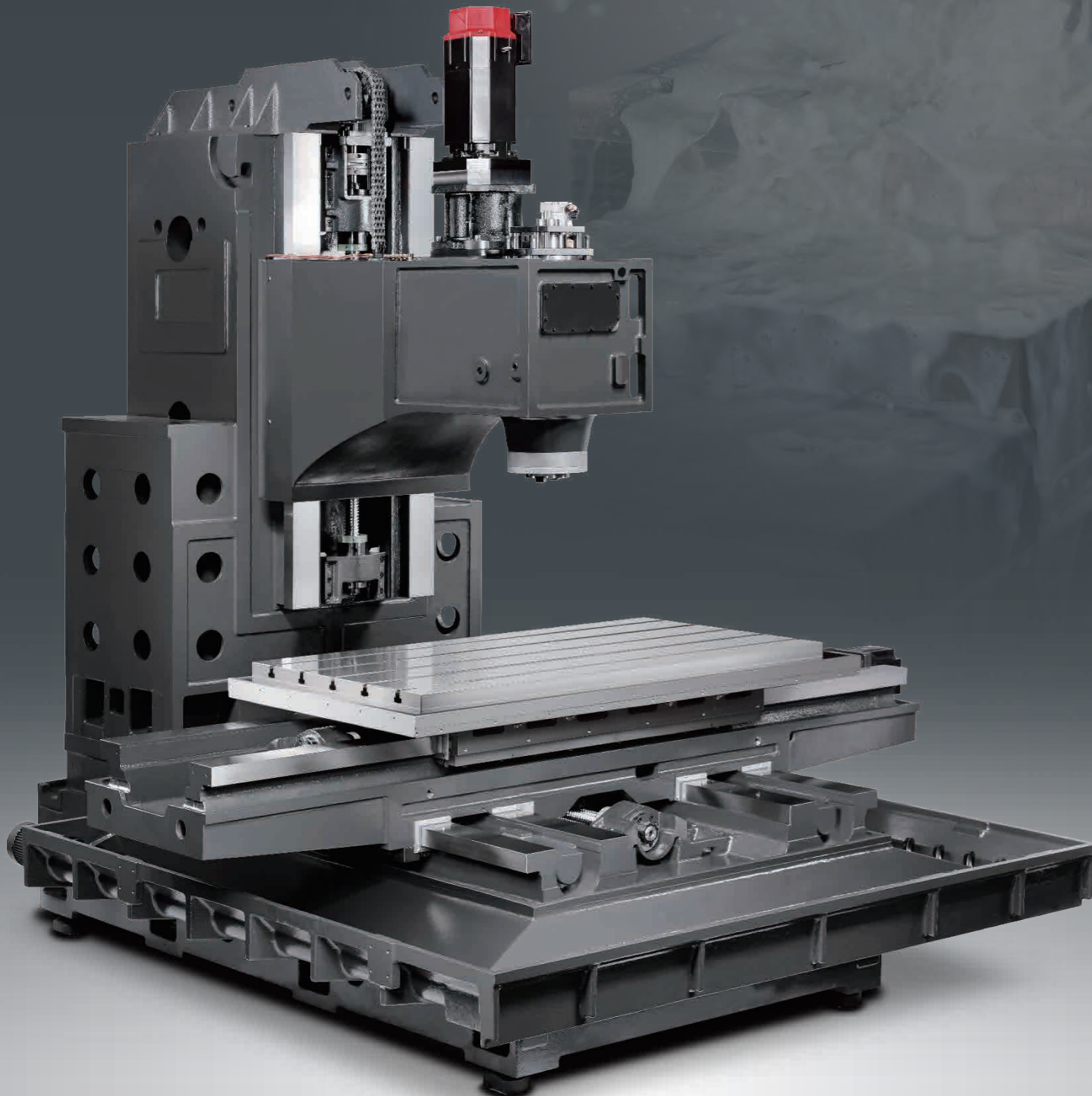

BM-1400 super rigidity structure



- Working table with double ribbed design to enhance the structure strength, while securing the table will not deform even load heavily for a long time.
- Copper piping auto lubrication system delivers metered amounts of lubrication to the slide ways, ball screws, and vital components with ensured reliability.

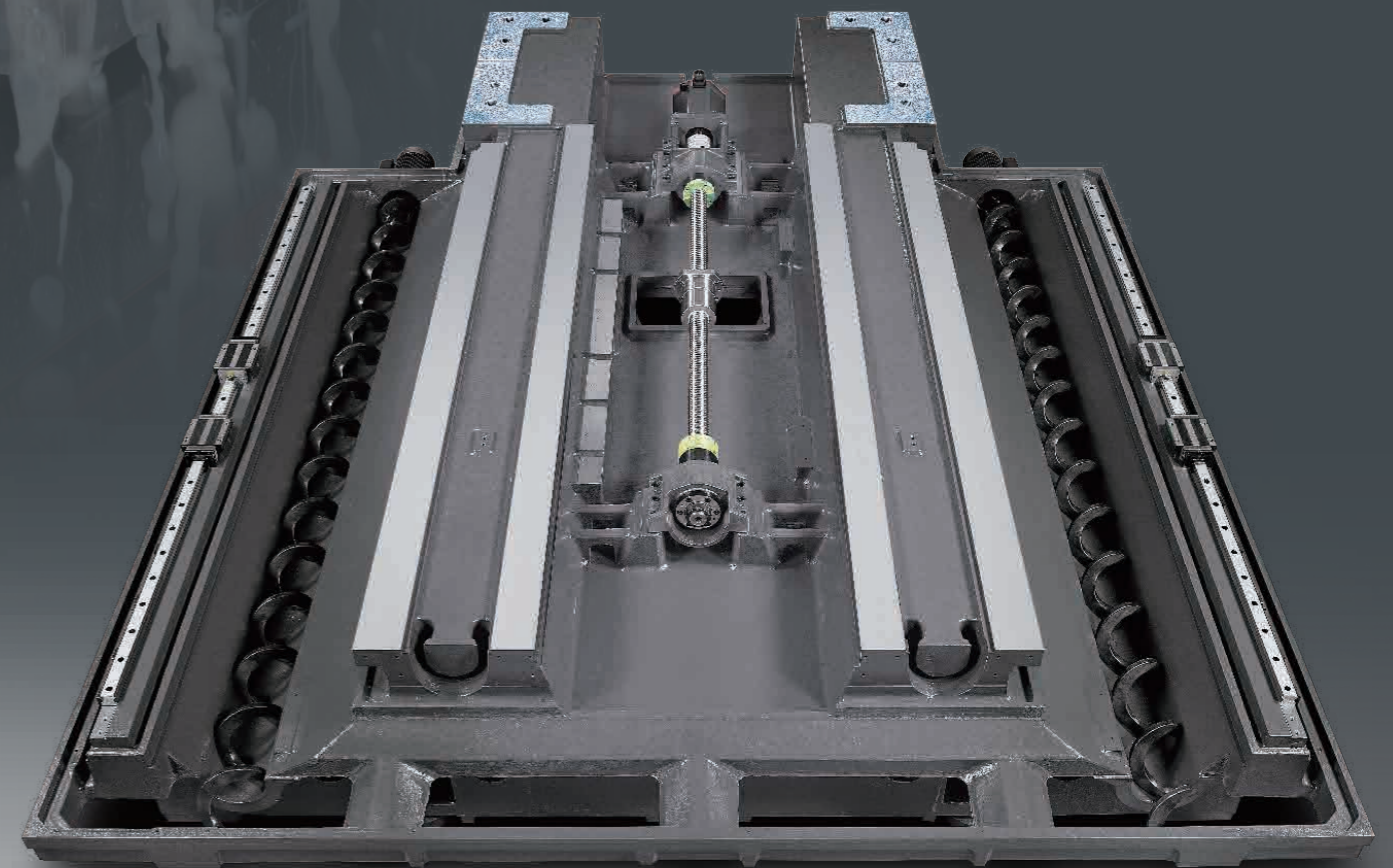
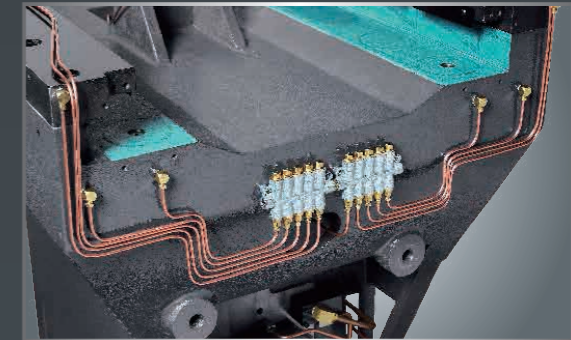

- BM-2100 / BM-2500, the table base is equipped with 6 guideways to solve over-hang problem and provide the fully support to ensure the rigidity.

High Performance Spindle System

- Gear spindle combines with High-Low 2 steps gear box design to provide large torque output
- High hardness Nickel-molybdenum-chromium alloy gear mechanism with auto lubrication and cooling system ensures the performance and lifetime of gear transmission box.
- High speed spindle and affordable belt type spindle options, which can be adapted with different kinds of spindle motor to fulfill variety of requirement.

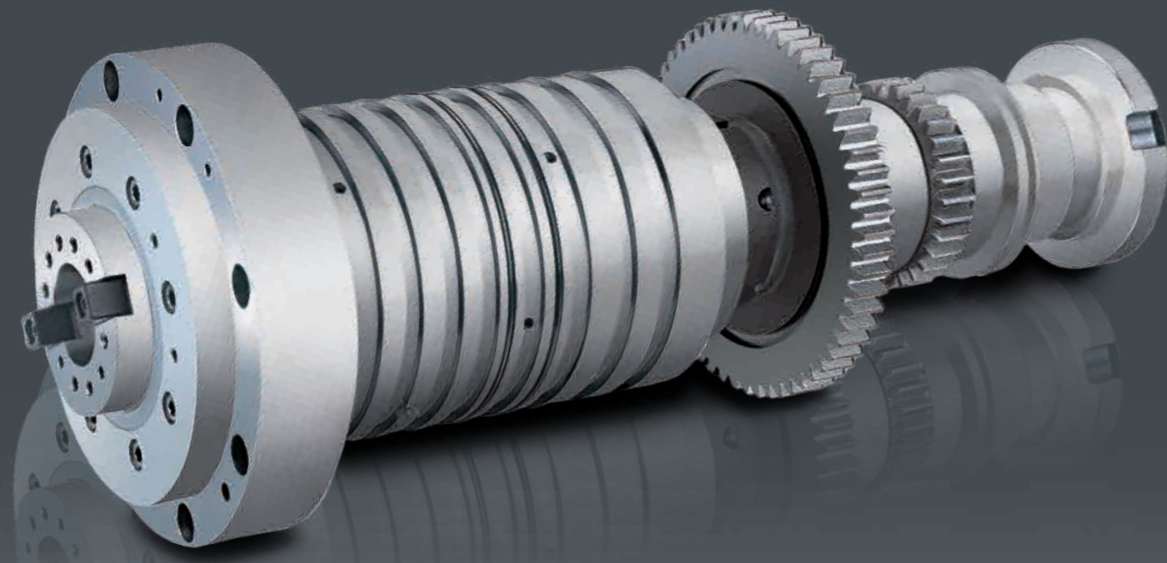

- Spindle, spindle motor, and gear box all pass through the completely running test ensures the performance and lifetime.



■ Spindle taper

Models	BM-850	BM-965	BM-1020	BM-1165	BM-1200	BM-1460	BM-1400	BM-1600	BM-1800	BM-2100	BM-2500
Standard				BT40				BT50		BT50	
Optional			BT50					BT40			--



Hand Scraped Craftsmanship



- All the sliding or fix surface of machine bed, column, saddle, headstock, and ball screw holder are hand scraped to provide excellent assembly precision and load distribution, ensuring long term accuracy.





High Speed ATC System

- BM series 24T arm type ATC system provide high speed tool exchange solution, and we also offer 30T / 40T arm type tool magazine to fulfill the variety of machining requirement.
- Standard shortcut tool change function can shorten tool change time and increase working efficiency.
- Ultra fast tool exchange system (opt.)

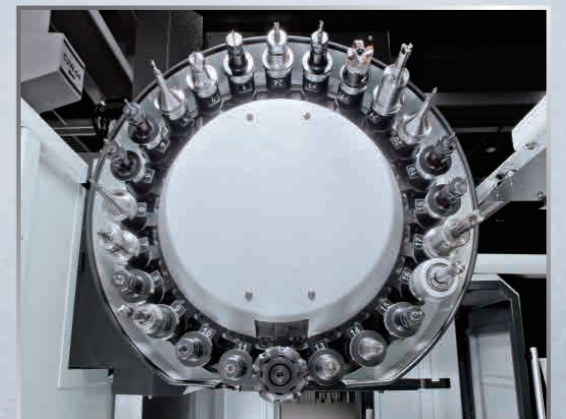

24T Disc type tool magazine



Chip Disposal System

■ All series are equipped with 1 / 3 / 5 screw type chip auger according to the machine size, thus to provide high chip remove efficiency.

■ The optional high pressure chips flush coolant system is also available.

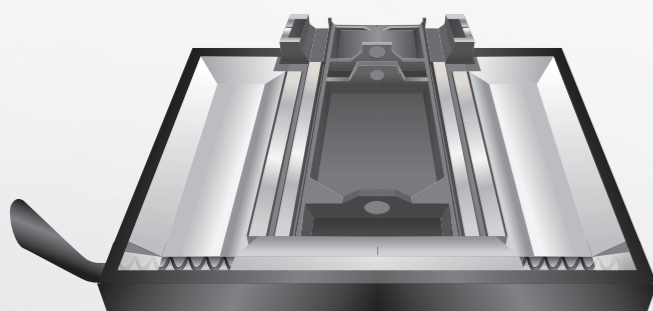

■ Screw chip auger x 1

BM-850 BM-1020 BM-1200 BM-1460

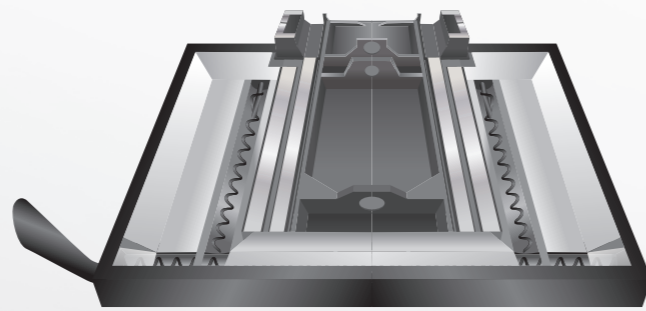

■ Screw chip augers x 3

BM-965 BM-1165 BM-1400 BM-1600 BM-1800

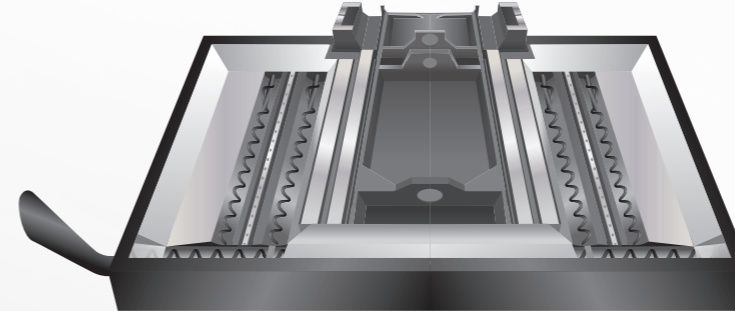

■ Screws chip augers x 5

BM-2100 BM-2500

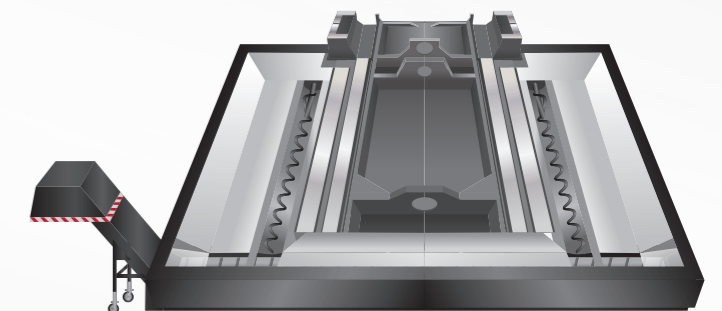

■ Chain type chip conveyor (Opt.)

High Efficiency APC System

In order to lower the labor cost and meet the requirement of high speed mass production, BM850-APC adapted with four box way, combines with APC system, which provides the best produce solution for automobile industry, especially suitable for gearbox, inlet manifold, or others parts.

i Console

AWEA's self-developed **i Console** intelligent software enhancement system provides you with a user-friendly interface, real-time machine status information and diagnosis functions. It not only effectively reduces complex working process but also increases intelligent machining abilities.

Option

(For 10.4" LCD only)



7 second
Auto pallet changing time

0.02 mm
Repeatability between two tables

Model	BM850-APC	Model	BM850-APC
X / Y / Z axes travel	850 / 600 / 600 mm	Spindle taper	BT40 / BT50 (Opt.)
Table size	460 x 800 mm	Spindle motor (cont. / 30 min.)	7.5 / 11 kW
Table rotating range	180°	Spindle speed	8,000 rpm
Repeatability for each table	0.01 mm	X / Y / Z axes rapid feed rate	24 / 24 / 20 m/min.
Repeatability between two tables	0.02 mm	Cutting feed rate	15 m/min.
Table load capacity	200 kg	Tool magazine capacity	24 T

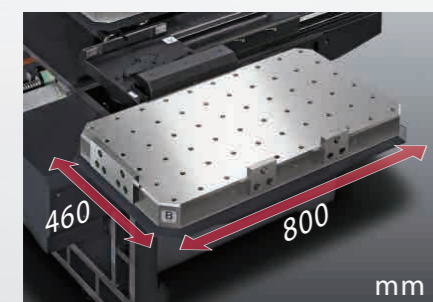

Table size

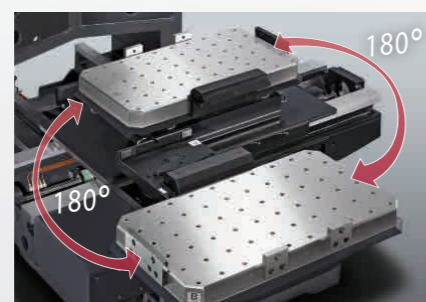

Table rotating range

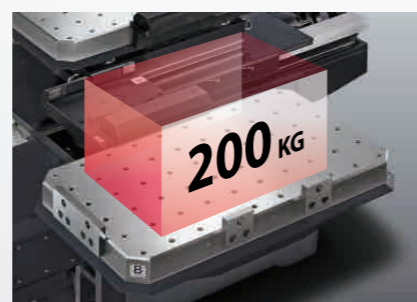
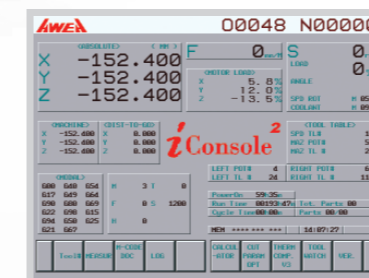

Table load capacity

Multiple Functions Status Display



- Real time operation information
- Tool list
- Work piece measurement
- M code illustration
- PLC function
- Calculator
- CNC optimize parameter (Opt.)
- Spindle thermal compensation (Opt.)

Circular Work Piece Measurement

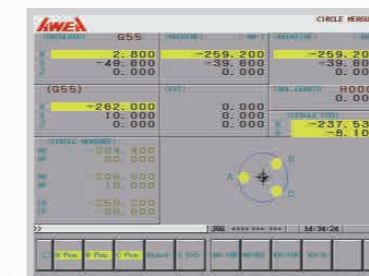

The circular work piece program can calculate the center coordinate of a work piece by measuring point A, B and C coordinates.

Rectangular Work Piece Measurement

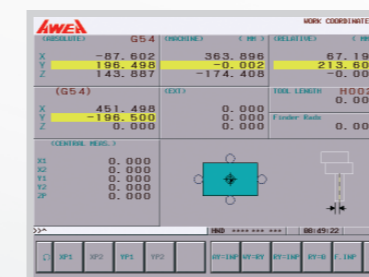

The rectangular work piece program can calculate the center coordinate and the slant angle of a work piece by measuring point A, B, C, D and E coordinates; the calculated center coordinate can be inputted into the work piece coordinate program (G54 ~ G59).

Trouble Shooting

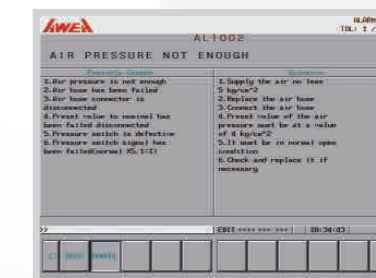

When the alarm appears, the program will display the breakdown cause and a troubleshooting procedure. Users can easily troubleshoot minor problems to save machine shutdown time.

CNC Optimized Parameter

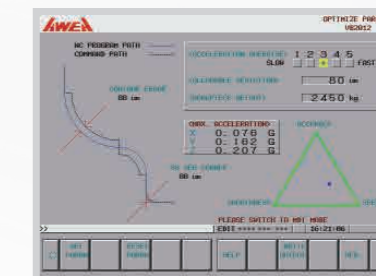

From rough cutting to fine machining, users can select different working modes, determine the allowable tolerance and the weight of the work piece, based on your desired working condition.

Manual Tool Length Measurement

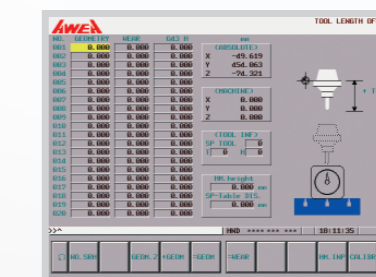

After manually measuring the tool length, the controller will automatically calculate the tool tip position and input the data into the tool length offset table.

Dimensions

(Unit : mm)

Table Dimensions

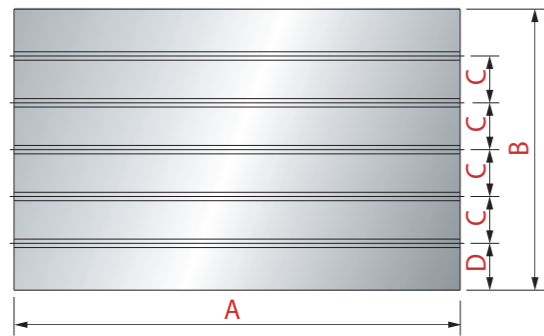

Models	A	B	C	D
BM-850	1,050	600	100	100
BM-965	1,100	650		125
BM-1020	1,120	600		100
BM-1165	1,200	650		125
BM-1200	1,300	600		100
BM-1460	1,500	650		125
BM-1400	1,700	800	150	100
BM-1600	1,700	800		100
BM-1800	2,000			100
BM-2100	2,300	1,000		50
BM-2500	2,700			
BM-850-APC	800	460	-	-

T-slot Dimensions

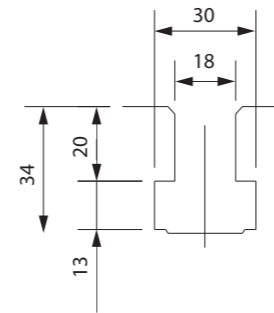

Tool Shank and Pull Stud Dimensions

BT40

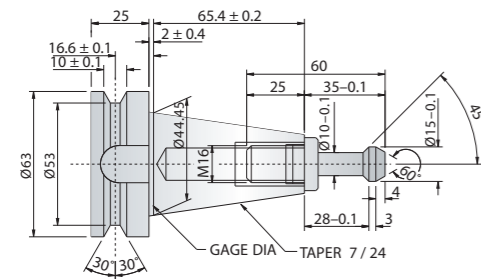

BT50

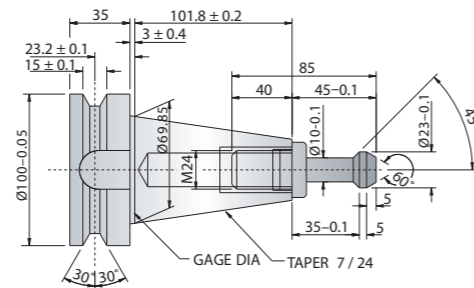

DIN40

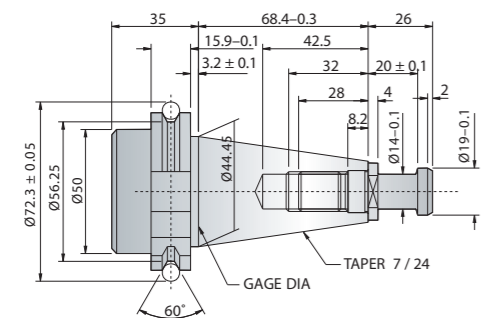

DIN50

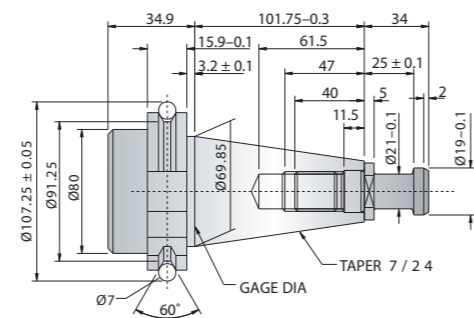

Machine Dimensions

BM 850 ~ 1460	BT40 40T : 695 mm BT40 60T : 1,385 mm
BM 1400	BT50 30T : 990 mm BT50 40T : 1,620 mm
BM 1600 / 1800	BT50 30 / 40T : 1,620 mm
BM 2100 / 2500	BT50 40T : 1,400 mm BT50 50T : 1,870 mm
BM 850-APC	BT50 40 / 40T : 659 mm

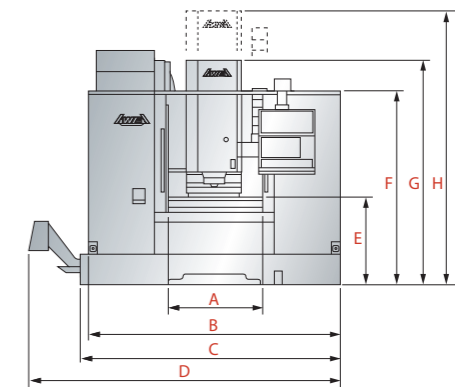
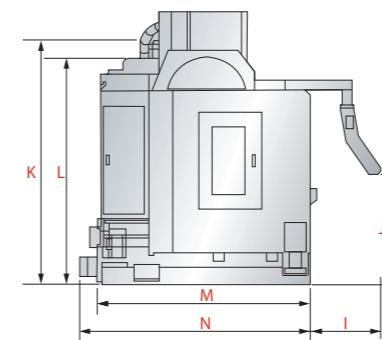
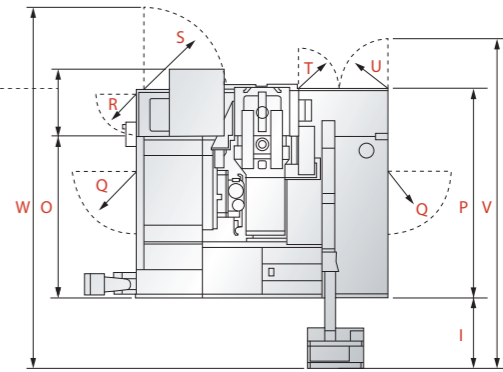

(Unit : mm)

Models	A	B	C	D	E	F	G	H	I	J	K	L
BM-850	1,000	2,600	2,600	3,135	900	1,900	2,125	2,725	730	1,140	2,520	2,340
BM-965	1,060	2,720	2,920	3,475	900	1,990	2,120	2,730	655	1,050		
BM-1020	1,000	3,000	3,000	3,535	900	1,930	2,125	2,725	730	1,140		
BM-1165	1,250	3,170	3,170	3,730	900	1,990	2,120	2,730	655	1,050		
BM-1200	1,300	3,400	3,400	3,935	900	1,930						
BM-1460	1,470	3,850	3,850	4,385	900	2,050	2,125	2,725	730	1,140		
BM-1400	1,500	3,950	3,950	4,640	960	2,180	2,605	3,305	735	1,135	2,875	2,675
BM-1600	1,800	4,400	4,400	5,090	1,050	2,330	2,585	3,385	725	1,160	3,330	3,205
BM-1800	2,070	4,880	4,880	5,570								
BM-2100	2,340	5,200	5,200	5,530	1,100	2,600	2,765	3,765	635	1,135	3,530	3,405
BM-2500	2,950	6,500	6,500	6,695								
BM-850-APC	850	2,600	2,800	--	1,050	2,150	2,400	3,000	865	1,000	2,670	2,490

Models	M	N	O	P	Q	R	S	T	U	V	W
BM-850	2,205	2,385	1,665	2,165	650	415	850	410	510	3,405	3,745
BM-965	2,230	2,420	1,730	2,330	660	380	860	470	470	3,355	3,740
BM-1020	2,205	2,385	1,665	2,165	650	415	850	560	560	3,455	3,745
BM-1165	2,230	2,420	1,730	2,230	660	380	1,085	470	470	3,355	3,965
BM-1200	2,205	2,385	1,665	2,165	650	415	1,050	560	560	3,455	3,945
BM-1460											
BM-1400	2,935	3,115	2,245							4,265	
BM-1600	2,965	3,145	2,230	2,930	900					4,255	
BM-1800								600	600		
BM-2100	3,550	3,730	2,660	3,500	--					4,735	--
BM-2500											
BM-850-APC	3,040	--	2,500	2,995	650			410	510	3,505	3,905

Specifications are subject to change without notice.

		BM-850	BM-965	BM-1020	BM-1165	BM-1200	BM-1460	BM-1400	BM-1600	BM-1800	BM-2100	BM-2500	
SPECIFICATIONS													
X-axis travel	mm	850	900	1,020	1,100	1,200	1,400		1,600	1,800	2,100	2,500	
Y-axis travel	mm	600	650	600	650	600		800			1,000		
Z-axis travel	mm	600				600		700	800			1,000	
Distance from spindle center to column	mm	680	710	680	710	680		900			1,100		
Distance from spindle nose to table center	mm	125 ~ 725				125 ~ 725		200 ~ 900	200 ~ 1,000			200 ~ 1,200	
WORKING TABLE													
Table size (X direction)	mm	1,050	1,100	1,120	1,200	1,300	1,500		1,700	2,000	2,300	2,700	
Table size (Y direction)	mm	600	650	600	650	600	650	800			1,000		
Table load capacity	kg	850	900	1,000	1,100	1,200	1,400	1,800	2,000	2,200	3,000	4,000	
SPINDLE													
Spindle taper		BT40 / BT50 (Opt.)				BT40 / BT50 (Opt.)		BT50 / BT40 (Opt.)			BT50		
Spindle motor (cont. / 30 min.)	kW	7.5 / 11				7.5 / 11		11 / 15			15 / 18.5		
Spindle speed	rpm	Belt-drive 8,000				Belt-drive 8,000		Belt-drive 6,000			Gear Spindle 6,000		
FEED RATE													
X / Y axes rapid feed rate	m/min.	24				24		20			15		
Z-axis rapids feed rate	m/min.	20				20		18			12		
Cutting feed rate	m/min.	1 - 15				1 - 15		1 - 12					
TOOL MAGAZINE													
Tool magazine capacity	T	24				24			24				
Max. tool length	mm	250				250			250				
Max. tool weight	kg	7				7		15					
Max. tool diameter / adj. pocket empty	mm	Ø 75 / Ø 150				Ø 75 / Ø 150		Ø 105 / Ø 210					
ACCURACY													
Positioning accuracy (JIS B 6338)	mm	± 0.01 / Full Travel				± 0.01 / Full Travel							
Positioning accuracy (VDI 3441)	mm	P ≤ 0.012				P ≤ 0.012		P ≤ 0.02					
Repeatability (JIS B 6338)	mm	± 0.003				± 0.003							
Repeatability (VDI 3441)	mm	Ps ≤ 0.008	Ps ≤ 0.006	Ps ≤ 0.008	Ps ≤ 0.006	Ps ≤ 0.008							
GENERAL													
Control system		FANUC Oi-MF / 31i-MB MITSUBISHI M80 / M800				FANUC Oi-MF / 31i-MB MITSUBISHI M80 / M800							
Pneumatic pressure requirement	kg/cm ²	6				6							
Power requirement	kVA	25				25		40					
Coolant tank capacity	liter	250	300	310		315	320	590	480		820	900	
Machine weight	kg	6,500	6,700	6,800	7,000	7,300	8,000	13,000	15,000	17,000	20,000	22,000	

Specifications are subject to change without notice.

Standard Accessories

- 3 axes auto lubrication system
- 3 axes ball screw pretension
- Spindle air curtain
- Coolant nozzle around spindle
- Air blow system
- Front side chip auger
- Two sides chip auger
BM-1400 ~ 2500
- Fully enclosed splash guard
- Rigid tapping
- Lubricating oil recovering system
- Heat exchanger for electrical cabinet
- RS-232 interface
- Tool box
- Air gun
- Water gun
- Alarm light
- Foundation bolt kit
- Automatic power-off system

Optional Accessories

- Arm type tool magazine 30 / 40T
- Belt-drive spindle BT40 10,000 rpm
- Gear spindle BT40 8,000 rpm BT50 6,000 rpm
- Direct-driven spindle BT40 10,000 rpm 12,000 rpm 15,000 rpm
- Gear spindle BT50 8,000 rpm 10,000 rpm
- Roof enclosed splash guard
- Coolant through spindle (Form A)
- Spindle thermal compensation
- X / Y / Z axes optical linear scale
- CNC rotary table
- Transformer
- Coolant through the tool adapter
- HEIDENHAIN , SIEMENS controllers
- Chips flush coolant system
- Caterpillar type chip conveyor & bucket
- Scraper type chip conveyor
- Automatic tool length measurement
- Oil skimmer
- Data server